

AUTOCAR

MALAYSIA SINGAPORE

autocarmalaysia.com | May 2020



Greatest 4WD heroes face off

THE VERDICT IS IN

DEFENDER DRIVEN

RATED Brilliantly capable on and off road



10-PAGE REVIEW
■ Every fact, figure
■ Tested to extremes
■ Full off-road specs



+ All the latest news and reviews

FANTASTIC NEW FORDS

All-new Kuga rated



+ New Puma: full road test



BMW i8



Why the bold BMW had to die

NEWS

- Ford Mustang Hybrid**, 4WD for next-gen muscle car **14**
- Audi A3 saloon** Sporty new four-door here in July **16**
- Aston's hybrid V6** Valhalla first, then it replaces V8s **18**
- Taking stock** Virus deals new blow to Aston's value **20**
- VW ID Buzz** Electric microbus to reinvent the MPV **22**
- Mercedes' battery bonanza** Bold new battery tech **24**
- Rise of touchscreens** Just how safe are they in cars? **26**
- REE speedwagon?** Start-up's radical EV platform **28**
- Ferrari's expansion** Two more new models imminent **30**
- Covid-19 response** How car makers are helping out **32**

TESTED

- Land Rover Defender** Tough three-day off-road test **4**
- Porsche 911 Turbo S** Greater pace and driving thrills **34**
- Audi E-tron Sportback** Rakish EV guns for I-Pace **40**
- Audi A3 Sportback** Big gains for all-new five-door **44**
- Mercedes-Benz GLA 250** More rounded than ever **48**
- Ford Kuga** Key family SUV arrives as plug-in hybrid **52**
- Porsche Taycan Turbo** Mighty EV rated on UK roads **56**
- BMW M8 Competition** 616bhp coupé on UK roads **58**
- Lamborghini Huracán Evo RWD** Entry level is best **59**
- Audi A8 L 60 TFSIe** Petrol-electric suits this limo **60**
- Volkswagen T-Roc Cabriolet** Sole VW drop-top rated **61**
- Ford Puma 1.0T 125 MHEV Titanium ROAD TEST** **62**

FEATURES

- Jaguar F-Type R vs Porsche 911** £100k shootout **70**
- Mini vs e-208 vs Zoe** Electric supermini shootout **78**
- BMW i8** We mourn the passing of a glorious failure **88**
- Quattro-phenia** Five of Audi's best fast 4WD heroes **92**
- Audi TT Mk1 vs Audi TT Mk3** Fond swansong for TT **100**
- Lambo legend's EV** Balboni drives us in Drako GTE **104**
- How to drift like a pro** Expert teaches a road tester **106**
- Steering feel** Does it matter new cars have less of it? **108**
- Rear-guard action** 10 rear-wheel-steer pioneers **110**
- Supercar superstar** The man with hundreds of them **112**
- Autocar at war** How we kept publishing during WW2 **116**
- Isolation for petrolheads** 50 fun ways to stay sane **120**

Autocar Malaysia Singapore
Managing Editor: Lisa Kuok
Editor: Breena Au

Autocar is published by Haymarket Automotive, Bridge House, 69 London Road, Twickenham, Middlesex, TW1 3SP. UKhaymarketgroup.com Tel +44 (0)20 8267 5000
Autocar magazine is also published in China, Greece, India, Indonesia, Japan, Korea, Malaysia, Philippines and Thailand.

Autocar is a member of the Independent Press Standards Organisation (IPSO). We abide by the Editors' Code of Practice and are committed to upholding the highest standards of journalism. If you think we haven't met those standards and want to make a complaint, contact autocar@haymarket.com. For more information, contact IPSO on 0300 123 2220 or visit www.ipso.co.uk

Haymarket is certified by BSI to environmental standard ISO14001 and energy management standard ISO50001



TROUBLE FINDING AUTOCAR?

If you struggle to find a copy of Autocar in your local retailer or area, please send an email to connor.chappell@hgroup.co.uk who will investigate the problem for you.



Autocar is a member of the organising committee of Car Of The Year caroftheyear.org

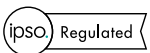

'LIKE' US ON FACEBOOK

Don't miss Autocar Malaysia Singapore every month. 'Like' our Facebook page and be the first to find out when we upload the latest edition.



NEW V8 JAGUAR GROWLS AT PORSCHE 911 **70**



FIRST DRIVE: MERCEDES-BENZ'S GLA **48**



GENERATION GAME: AUDI TT MK1 vs TT MK3 **100**



“DUE TO THIS PANDEMIC, IT WILL BE BUILT MORE SLOWLY AND TO A HIGHER STANDARD”

COLIN GOODWIN WILL USE ENFORCED TIME AT HOME TO BUILD HIS BEST CATERHAM YET **120**

COVER STORY



DEFENDER PROVEN IN THE WILDS OF AFRICA **4**

THIS MONTH

COMMENT

AND THE LOCKDOWN CONTINUES



THE EAGERLY ANTICIPATED Land Rover Defender got a full workout in Namibia and this month, we share the outcome of three days under tough conditions. The 10-page review starts overleaf.

Only the boring get bored, so it's been said. Sometimes, it's not a lack of imagination but a brain freeze. This month, we feature 50 ideas for petrolheads to keep themselves occupied over the ongoing Stay At Home.



There's not going to be a second-gen BMW i8. Speaking as a great fan of the car, why? All is revealed on page 88.

Want to learn a new skill during the MCO? Learn how to drift like a pro, within the safety of these pages.

Other must-reads include 40 years of Quattro, Tom Hartley the supercar dealer at his new showroom, and how, through the Second World War, bombings and shortages, this great magazine carried on publishing, uninterrupted.

Finally, Selamat Hari Raya to our Muslim readers. Stay safe and well and enjoy the stories we've curated for you this month.



NEVER MISS AN ISSUE
'Like' us on Facebook

Lisa Kuok
Managing Editor
lisa@blackdogmedia.asia

FIRST DRIVES

NEW CARS TESTED AND RATED



TESTED 22.2.20, NAMIBIA ON SALE MAY PRICE £49,880 (€66,000 AS TESTED)

LAND ROVER DEFENDER 110 S

Does the new Defender have the off-road prowess to justify its name - and how does it drive? Cue three tough days in Namibia





Our knobby-tyred, air-suspended cars rode the rare stretches of Tarmac with a forgiving gait

I don't know if it's bold or reckless to launch a Land Rover in Namibia. Not because of the barrenness, what with it being the second least densely populated country on earth, having a land mass three and a half times the UK's but only 2.5 million inhabitants. Not because the terrain is challenging and so vast that there's a national park the size of Belgium.

No, it's because the default car of choice is a Toyota.

It's not that you don't see Land Rovers. Walk around the capital, Windhoek, and you'll find Range Rovers as you will everywhere money lives, but out in the wilds – and Namibia is second only to Mongolia when it comes to wilds – the Hilux is king. Namibia is a country where four in 10 brand-new cars are Toyotas, where it used to be a much higher percentage than that, and where the Hilux's capability and longevity mean that, in the places you'd really want to test a Defender, the cars that aren't Hiluxes are other beaten-up Japanese pick-ups. There are a few old series Land Rovers going on adventures, but the working or adventuring truck market is one, you have to conclude, the Defender left some time ago.

What does it want to be now? Well, this is it, the new Defender, the most difficult vehicle to replace since Volkswagen tried to reinvent the Beetle. The old car had a separate chassis because that's how you did things in 1948 and, although updated during its life, true modernisation

had probably faltered by the 1980s and the Land Rover hasn't been a ubiquitous, everyman's vehicle for most of this century.

And so, as with the modern Mini, the Fiat 500 and the new Beetle, the reinvention comes. Not an easy task. "All of our marketing blah-blah about reinventing an icon is true, I think," says Felix Bräutigam, Jaguar Land Rover's chief commercial officer, who has joined us for the drive and, having worked at Porsche (and with a 911 GT3 RS 4.0 and the last-ever manual Jaguar F-Type in his garage), I think you'd like him a lot.

"The 60-second elevator pitch for the Defender is 'capability,'" he says. "This is not a sport utility vehicle. It's a 4x4."

Interesting distinction, and not one I often make. What else is a 4x4,

not an SUV? Search Jeep Wrangler, Mercedes G-Class and Toyota Land Cruiser and you'll find their makers all file them under 'SUV', but Bräutigam has stripped out the term in Defender literature. Land Rover would like you to think this is the real deal, a Land Rover like no other. "Land Rover is a three-legged stool again," he says.

Is it like the old one? If you imagine Land Rover development had continued in, say, Porsche 911 or Honda Civic style, with regular updates and model cycles and some technology step during each one, is this where you'd end up?

I don't think so: the new Defender, one of the most capable vehicles on earth though it may be, is pitched where the previous Defender left off, as a premium want-vehicle, not as →



Wading limit is a very generous 900mm so this poses no problem

LINE MANAGEMENT

In 2017, I drove from London to Slovakia to see a piece of flat ground on which 4000 people were constructing a 300,000m² factory that would have an output of 150,000 cars a year. The Discovery was slated for production there at the time, with Land Rover – which hadn't announced this Defender then – staying schtum about what else would come, but it wasn't hard to work out.

Today, the Defender and Discovery, based on similar architecture, roll back to back down the same Nitra production line. Outline plans and permission does exist to double the factory's size and output, although with where the world is at the minute, who knows when that's likely.

Replaying that drive today, consisting of mile after mile of motorway, the Discovery would probably remain the choice. But the Defender's gentle demeanour, better infotainment and, I suspect, easier manoeuvrability in town would run it close.





“
At the start of the drive, I'm
told: 'We won't see Tarmac
for another three days'
”



TESTER'S NOTE

Coil-sprung cars will run the same ride height as air spring cars on the standard setting - slightly reducing max ground clearance and wade depth accordingly. **MP**

“
What's striking is how easy
the Defender tries to make all
of this crawling and wading
”



Five-door 110s and three-door 90s will make a splash when the first Defenders arrive in May

◀ the need-vehicle that is how the original series Land Rover began its life.

A 911 has always been a sports car, the Civic always a family runabout. But I think the Defender has changed. That's not necessarily a bad thing. It's just a thing.

We can discuss its looks - I will as we go on - but the trouble with assessing design is not that you and I think differently, but that as familiarity sets in, even our respective views change. I already feel differently from how I did when I saw this car last year, for better and worse.

The hardware, then, is where objectivity lies. Underneath the body, with its bluff back end,

reassuringly familiar side-opening tailgate and three- and five-door variants badged 90 and 110, sits a derivative of Jaguar Land Rover's big aluminium D7 architecture.

Don't think that means it's overtly based on something else: the platform has a suffix for different models, so a Jaguar XE is a D7a and a Range Rover is a D7u and even a Jaguar I-Pace is D7e. But it means there are shared modules and crash structures and, notably, commonality in the expensive bit between the front axle and the dashboard.

But the new Defender's aluminium shell, in all of the body-in-white and not just the outer panels, is unique to this car. It sits higher than on any other Land Rover, too.

Attached to the bonded and riveted shell are steel subframes front and rear, with independent suspension all round - wishbones at the front, integral link at the back. No, it doesn't have a separate steel chassis any more and nor is there a solid axle to be seen, as you'll still find front and rear on a Wrangler and beneath the back of a Land Cruiser, G-Class and every pick-up. But Land Rover claims a 29kNm/deg torsional stiffness, a 900kg maximum payload and a towing limit of 3500kg (3700kg in the US).

Engine options are 2.0-litre diesels with 197bhp or 237bhp, a 2.0 petrol with 296bhp and a 3.0 V6 with 396bhp. A plug-in hybrid is coming soon: "We didn't want to make a

last hurrah of a pre-Greta era," says Bräutigam. "This is a justifiable car." For now, though, we're driving the most powerful diesel and petrol.

All engines drive through a ZF eight-speed automatic gearbox. There's no manual option and I doubt there will be. There's an electronically controlled centre and rear differential and the Defender gets Land Rover's Terrain Response system, so it is not a car with which you can choose to lock the differentials as you can in a Wrangler or G-Glass. But it does have a low-ratio transfer case and, remember, despite each wheel's independence and the unitary body, it's not an SUV. Well, we'll see.

Later, base models will have coil springs as standard, but early cars -



TUSK TRUST (AND RED CROSS) PART OF TEST TEAM

The Tusk Trust runs 50 projects across 20 African countries trying to conserve wildlife. It's called Tusk but the charity goes further than just trying to save things with horns. It's looking out for "anything under threat", says founder and CEO Charlie Mayhew. That includes the poor pangolin - hunted for medicine and as a delicacy and thought by some to be the transmitter of the coronavirus to humans. You'd have thought its hard scales would have made it obvious it didn't want to be consumed, but there you are. People. Anyway, Tusk's work revolves around getting local communities

to "view wildlife as an asset rather than a threat", to combat the annual £15 billion illegal wildlife trade. And to maintain habitat, which is under great pressure from the human population explosion. I'm telling you this not simply because Land Rover supports Tusk "not just with cars, but with money", but also because Land Rover has had Defenders out with Tusk and organisations like the Red Cross during testing. Not only out of the goodness of their hearts, but "they are one of our target groups", says Jaguar Land Rover's Felix Bräutigam, "because it's good business".



we've driven two 110 variants, with 90s coming later - will run on air springs, one of a raft of technologies that serves to improve the Defender's off-road capability. We'll test that a lot here. "Once through these traffic lights," I'm told at the start of the drive, "we won't see Tarmac again for three days."

I've done enough off-roading to know that this can be quite tiresome, that after three straight days of driving off road, a stretch of smooth asphalt is like a hit of warm sun at the end of winter.

The Defender sets a good first impression on cushioning the blow. There are trad Defender cues - a big slab of dashboard with a grab handle at either end, with the instruments →

Side-hinged tailgate is a nod to the original Defender, as are some of our test car's accessories

HOW THE DEFENDER'S OFF-ROAD STATS COMPARE

When listing the most capable factory-fresh off-roaders, there are a few standouts – the Ford Ranger Raptor and Jeep Wrangler the two most notables, in my experience.

The numbers suggest how capable the Defender will be against them – although because they have separate steel chassis and the Defender

doesn't, it's feasible you won't mind bashing the underside of them as much as you will the Defender's.

But in terms of raw numbers, especially approach and departure numbers, the Defender – at least, on air springs, in maximum height – has nothing to fear. A full back-to-back test will follow later in the year.

LAND ROVER DEFENDER

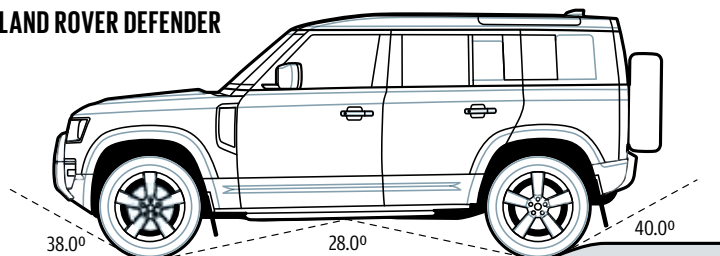

Wade depth: 900mm

Ground clearance: 291mm

JEEP WRANGLER

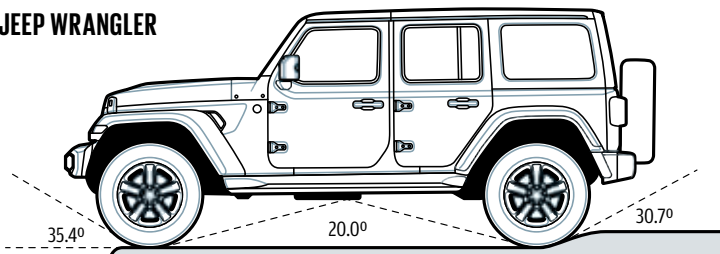

Wade depth: 760mm

Ground clearance: 242mm

FORD RANGER RAPTOR

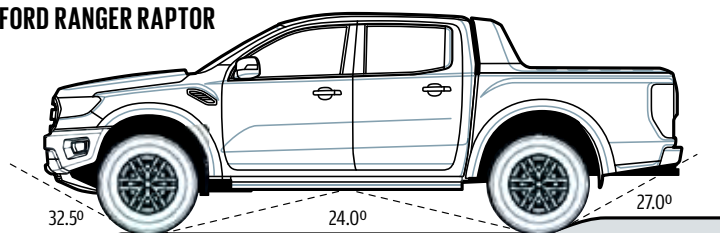

Wade depth: 850mm

Ground clearance: 283mm

← in their own little binnacle. The steering wheel is huge, driving position high, seats large (that's new) and visibility good (that's not new). You can see where the car ends, where its sides are, and the door mirrors are big, too. As well they might be: while the old Defender was as narrow as a Ford Fiesta and as long as a Ford Focus, this new model is 2105mm wide across its mirrors and 5018mm long, including the spare wheel – a luxury car footprint with Land Rover's longest wheelbase, at 3022mm. The 90 is half a metre shorter in both wheelbase and length.

Interior materials feel good, albeit this is a higher-spec car. There are some exposed structural elements and Torx-head bolts to enhance the adventurous feel; although that's better achieved by the amount of storage space and charge outlets the Defender brings you, which, as you'll know if a lot of you are travelling for a long time, is what really matters. And there's a new infotainment

system. Touchscreen, yes, but it's good. No, I mean it. For the first time in a Land Rover, it's genuinely quick, clear and confident.

You can have two or two-and-a-bit seats in the front, with a middle jump seat you'd use to get a lift home from the pub but for no longer than that. There are three seats in the rear with massive head and leg room – the top window is a nice touch but no more than a distant porthole – and you can spec two seats in the spacious boot (although not with the jump seat). The boot, at 916 litres to 2233 litres with the second row folded, is cavernous, and although you'd probably get a wider access hatch if the tailgate lifted, rather than swung sideways, remember it's a Defender.

The control weights are not traditional Defender. They're light, positive, progressive and, as we mooch out into the countryside, it feels easy and laid back. I think that's important in a car that claims to be so capable; a Land Cruiser manages

it in similar fashion. If you're going to spend a long time in one of these, in abnormal road conditions, you'll want a car that's ergonomically easy to rub along with. You can make a case on a car's various ultimate off-road credentials (and see the hard numbers, above left) but reducing fatigue counts.

The ride feels easy, too, on big empty roads where it lopes along with plenty of breath in its lungs. The steering doesn't tell you much or self-centre greatly but it's accurate and stability is good.

A few caveats: we're largely on rough roads – a brief stretch on asphalt suggests the Defender is an engaging road drive too. The steering gains weight and response as forces build, the ride's composed, pliant, but with tight body control and well-contained roll. And we're on knobby tyres rather than more road-biased ones. Also, there's a roof rack and ladder and a bunch of kit on top of the car, which probably doesn't help

dynamics, so I'm impressed that the Defender feels so sure-footed.

The reason for the tyres and the kit, of course, is the terrain. Namibia has all of it. In places, it's rocky, with oodles of small loose stones or big solid ones, but all able to snag a tyre sidewall. And at times, it's sandy, dune-like or more solid or in a riverbed, which when we drive through is flooded with sufficient water to make for a tough wading test, with thick mud beneath. Bar slippery grass, which will be the standard UK test, Namibia has got everything.

What I do like about the Defender's design is how it interacts with its surroundings. The drag coefficient is a reasonable Cd 0.38 but there's still been the chance to leave little shelves around the lights that attract and trap dirt and dust; an old Defender does the same and it's something that would be annoying on a BMW 3 Series but works nicely here.

How well the Defender's appearance will otherwise mature →

“
The reason for the knobby
tyres and the extra kit is the
terrain. Namibia has it all
”

Defender tackles terrain like this with an indomitable yet easy-going manner



Launch line-up runs to 197bhp and 237bhp 2.0 diesels and 296bhp 2.0 and 396bhp 3.0 petrols. Low-ratio gearing is standard



◀ I don't know, but following one today, it's novel and largely avoids caricature. In essence, Land Rover admits it gives Discovery 4 owners a car to move on to, but in design terms, there are also shades of first-generation Freelander about its stance when you see it moving.

The Defender is equal to whatever terrain we put its way. It's hard to say how much better or worse than the key rivals it is (even when we do conduct back-to-back testing in the UK, we'll find muddy ground can change as we drive over it, making exact replication hard). But the raw numbers are strong, particularly with the suspension on its highest setting. And with the gearbox in low ratio, both the diesel but more so the petrol have decent urge. The diesel can get a little bogged as you try to keep momentum along soft riverbeds (it is a 2248kg car) and, with no separate chassis, there are no slide rails at the back, but the rear overhang is short, the floor flat, and the front bumper and skid plate the lowest part of the car – so if you clear objects with those, it should clear all the way along.

What's striking, though, and unusual, is how easy the Defender tries to make all of this crawling and wading. In a Wrangler, it feels like off-roading is how you challenge yourself, as you choose to lock the differentials and disconnect the anti-roll bars via cabin switches. Wranglers are incredibly capable, and I love them for it, partly because they make off-roading feel like a hobby.

The Defender tries not to make it a chore. As standard on the models you can spec at the moment is the Terrain Response system that manipulates suspension, differentials, brakes, traction control and more on the go. It also has 360deg cameras, including a through-bonnet one showing the front wheels, and even a wade sensor that tells you when you're approaching its 900mm depth limit – in case water approaching the windows doesn't let you know. That means you have to get out of the car less, fiddle with buttons less, poke a stick into a stream less, and stay comfortable and at the right temperature more. Tick a couple of boxes and fit the right towbar and it'll even tell you how much weight is on the towball and run a trailer tail-light check without you having to leave your seat.

And, yes, are there ever boxes to tick. Prices for five-door Defenders start at £45,000 but, in the specification you see here, the 2.0-litre diesel comes in at around £65,000 and this P400 petrol more like £87,000. Bräutigam admits that early-ordered cars are a "rich mix". Although a commercial Defender will start from around £35,000, it's also possible to spend £100,000 on a heavily optioned five-door.

Which leaves the car where, exactly? Doing some things and costing similar to other Land Rovers,



Launch models have a standard-fit wade sensor, should you need to use it

perhaps? It's an argument I've considered before but a BMW X1 overlaps an X2, which does an X3 and so on through 4, 5, 6, 7 and 8, so does this matter? Over three days of musing, I never quite square myself with the price, either, once optioned, but the car's certainly no less impressive – and no more fatiguing – even after hundreds of tough miles.

I keep wondering which car I'd rather be in as terrain changes underfoot. Sometimes a Wrangler (three-door, with a Mopar lift kit, for rock crawling), sometimes a Ford Ranger Raptor (fast on sand), and if I lived in Namibia, I suspect I'd have a Toyota. But whatever the terrain, the Defender would never be out of my top two or three choices, and proper road, where it's extremely amenable, returns as just another surface, not as a relief. Admittedly, there's a price, but be in no doubt: this is one of the most capable vehicles in the world.

MATT PRIOR

[@matty_prior](#)

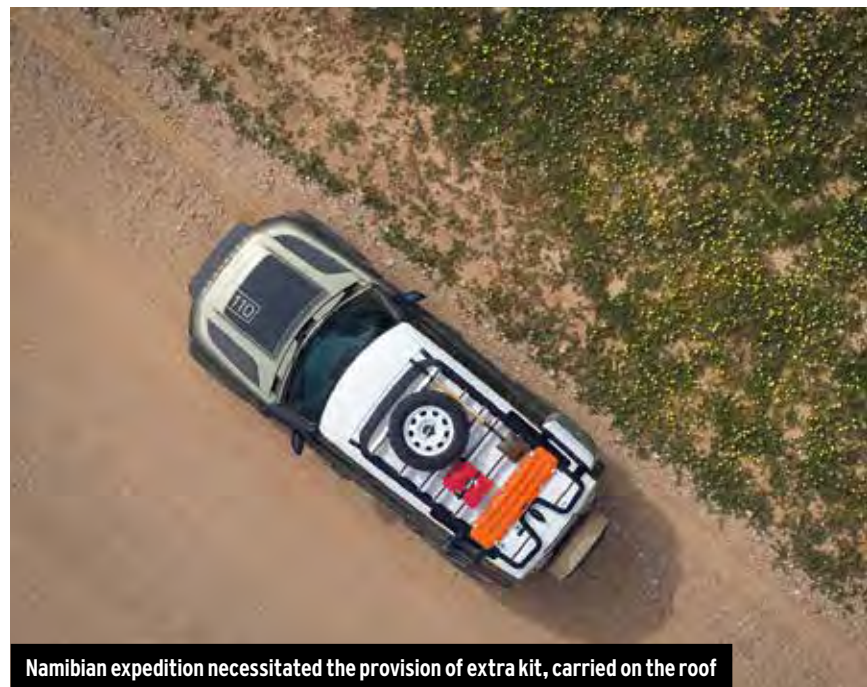

Namibian expedition necessitated the provision of extra kit, carried on the roof

“
The new Defender is
equal to whatever terrain
we put its way
”



VAN VERSIONS NEXT BUT PROBABLY NOT PICK-UPS

So far, then, two lengths - 90 and 110 - of the Defender have been confirmed and commercial versions will be available on each. The rear seats will be removed and the side windows blanked, and the carpets removed and replaced with a hard-wearing floor.

Payload for both is 900kg, with 90 prices set to start at £35,000 - making them fairly premium vans,

but commercial vehicles nonetheless.

We think there will be a 130 version with some extra length behind the rear wheels, but while previous Defenders came as pick-up or as chassis cab, too, having no separate chassis doesn't make that so straightforward. Bear in mind, too, that pick-ups need a payload of more than 1000kg to qualify for tax breaks and that might be hard to achieve.



Perceived quality of our (higher-spec) car's cabin trim was high, the design practical and the infotainment system good

LAND ROVER DEFENDER 110 S

One of the world's most capable vehicles, at a price



Price	£49,880 (base, £66,000 as tested)
Engine	4 cyls, 1999cc, turbocharged, diesel
Power	237bhp at 4000rpm
Torque	317lb ft at 1400rpm
Gearbox	8-spd automatic
Kerb weight	2248kg
Top speed	117mph
0-62mph	9.1sec
Economy	31.7mpg
CO₂, tax band	234g/km, 37%
RIVALS	Jeep Wrangler Rubicon, Toyota Land Cruiser

NEWS

GOT A STORY?

Email our news editor
info@autocarmalaysia.com



New Mustang to go four-wheel drive with hybrid V8

Electrified V8 will spearhead the 2022 arrival of the next-generation Ford Mustang

Ford's muscle car icon, the Mustang, will enter its next generation in 2022 – and Autocar understands it will be brought into a new era with its first hybrid powertrain.

An electrified variant of the Mustang will join the electric Mustang Mach-E, which is due to be delivered to customers from this autumn, as Ford's electrification roll-out gathers momentum. Ford plans to launch 18 mild-hybrid and full-hybrid models by 2022,

and the next Mustang is thought to be one of those.

The firm is hoping for the new model to build on the success of the current, \$550-generation car, which has been on sale since 2015 and was the first Mustang to be marketed and sold globally. This meant the first-ever right-hand-drive Mustang sales were finally made possible. Ford has shifted 55,000 examples of the current car across Europe – more than ever before

in the Mustang's history.

The next-generation Mustang, codenamed S650, will follow that template by making a return to mainland Europe in left-hand drive and the UK in right-hand drive, Autocar understands.

The new Mustang would have arrived far sooner were it not for a reversal of product plans. In 2017, Ford announced it would bring a hybrid Mustang to market in 2020. But that same year, Jim Hackett

stepped up to the role of Ford CEO and decided instead to prioritise getting a Mustang-inspired EV, the Mach-E, to market as its long-awaited first mass-production electric car.

Now that the Mach-E has been developed and its launch is around the corner, attention has turned back to the standard coupé and convertible Mustang models, which are still expected to dominate sales of the nameplate for some time yet.

Ford is hoping to appease its loyal following of enthusiasts by retaining the V8 option, but this time it will be mated to a fuel-saving hybrid system.

A US patent filed by Ford in 2017, when the original plan was in place, refers to technical drawings of a “twin-motor drive system for hybrid vehicle”. These show an eight-cylinder engine in a vee formation sending power to the rear wheels – a classic Mustang trait. But the filing

Current Mustang's
basic character
will be retained



“
It remains to be seen if Ford will also
offer a non-hybrid V8 option and a
turbo four-cylinder engine
”

also details battery assistance in the form of two electric motors “mounted directly to opposing sides of the engine”.

This means such a model would have four-wheel drive, with electric-only power heading to the front axle and, in performance driving, stepping into play when

the car's rear wheels lose traction. The system could offer torque vectoring, too.

In more eco-minded modes, that same set-up would allow the engine to be shut off in situations with low power demand and high battery charge, boosting efficiency. A similar powertrain concept

is used in the recently launched Ford Explorer Hybrid in the US.

A likely factor in the decision to go hybrid is Ford's intention to base the next Mustang on the same CD6 platform as the Explorer SUV and its sibling, the Lincoln Aviator. In 2018, the company announced it was streamlining its platform line-up with five highly modular underpinnings, including one to cover all rear-wheel-drive/four-wheel-drive unibody-construction cars (such as the new Explorer and next Mustang, among others).

However, it remains to be seen whether Ford will offer alongside the hybrid a cheaper, non-hybrid V8 option and a turbocharged four-cylinder engine, as are available today. Ford recently dropped

automatic versions of the four-pot Ecoboost Mustang in the UK due to their low efficiency. It's also unlikely that a traditional V8 without some form of electrification would continue in Europe, given the need to meet stringent fleet average emissions targets.

As for the new Mustang's design, we're expecting it to stray not too far from the formula so well loved by its customer base. The muscle car's shape has gently evolved over the decades and, given the Mach-E takes inspiration from today's Mustang and will be on sale alongside the new car, it should be recognisable, albeit with a more modernist approach to the detailing. However, we've yet to see any disguised test mules to give us

a clear indication of its shape.

It's likely that a convertible version will again appear, despite some makers moving away from that market, because the drop-top still makes up a significant proportion of Mustang sales.

Inside, expect the Mustang to be more driver-focused than the tech-heavy and space-maximised Mach-E.

The infotainment and driver assistance systems on that car are expected to be moderated for their introduction in the Mustang.

The four-seat layout should continue largely as it is today, with engineering developments ensuring the hybrid system has a minimal effect on interior space.

LAWRENCE ALLAN

Mach-E is tipped to
give style pointers
to the new Mustang



New A3 saloon is longer, wider and taller than today's

“The standout engine is a 148bhp 1.5-litre TFSI petrol unit with 48V mild-hybrid technology”



Audi tees up sporty A3 saloon

New four-door has a more coupé-like look and is 'more precise' than its predecessor

The new Audi A3 saloon adopts the same technologies as the recently revealed A3 Sportback, with mild-hybrid powertrains, refined suspension and a heavily revised interior.

Stylistically, the second-generation A3 saloon is only a subtle update of its predecessor but it is intended to have a more coupé-like appearance.

Although the saloon accounts for only a fifth of overall A3 sales in the UK, the bodystyle is popular in other markets, such as China, as proven by the recent flurry of new introductions in the segment, including the BMW 2 Series Gran Coupé and Mercedes-Benz A-Class saloon.

The booted A3 is longer, wider and taller than before,

creating an extra 2cm of head room in the front and more elbow room, while boot space remains unchanged, at 425 litres. The car sits on the same updated MQB platform as the new Volkswagen Golf. The platform is claimed to be lighter yet also more rigid than the one it replaces.

The car receives digital daytime-running lights, made up of 15 LEDs, for the first time. Certain trim derivatives have an individual light signature to set them apart.

Aerodynamics are better than the outgoing model's thanks to a higher rear end and large diffuser. The car

achieves a Cd value of 0.25, 0.04 better than previously. A controllable cooling-air inlet with two electrically actuated louvre modules behind the grille regulates the flow of air according to the situation.

The standout engine is a 148bhp 1.5-litre TFSI petrol unit with 48V mild-hybrid

technology, first announced in the A3 Sportback. Available only when paired with Audi's S tronic seven-speed dual-clutch transmission, it can recover 16bhp during deceleration, supports the engine with up to 37lb ft of torque at low speeds and can coast with its engine off for up to 40 seconds. It promises a 10% improvement in fuel consumption and CO₂ emissions as low as 107g/km.

There are two other powertrain choices at launch: the same 35 TFSI engine with 148bhp but mated to a six-speed manual transmission and a 2.0-litre TDI diesel also delivering 148bhp and paired with a seven-speed S tronic dual-clutch automatic.

Later, a 114bhp 2.0-litre TDI diesel will arrive alongside a 108bhp 1.0-litre 30 TFSI three-



Higher rear end helps to improve the new A3 saloon's drag coefficient, which is now as low as 0.25Cd

STAY OF EXECUTION FOR MULSANNE

The end for the Mulsanne has been delayed due to the pandemic. The 30 examples of the run-out 6.75 Edition by Mulliner will be hand-built by Bentley's bespoke arm when production resumes and are expected to be completed by late summer.



CAR FIRMS RE-OPEN EUROPEAN PLANTS

A number of car makers - including Hyundai, Audi, Renault, Daimler and Suzuki - have slowly begun to restart car or engine production across Europe. Volkswagen has also re-opened its Zwickau plant, where the ID 3 is being built, and a site in Slovakia.



Polestar opens door on future



Infotainment touchscreen is joined by a digital instrument display

POLESTAR HAS RELEASED new images of its Precept electric saloon concept, which CEO Thomas Ingenlath has called a showcase for the brand's future.

The concept was first unveiled in February, just before the cancelled Geneva motor show. Ingenlath has stressed that this model has real relevance to the brand's forthcoming products, strongly hinting that there's production intent for a Tesla Model S rival inspired by the Precept within the next few years.

He said: "Precept shows you where we will be heading - our design direction, our ambitions about sustainability and the great digital user experience

we will bring with those future cars. Precept showcases our future, not a fancy dream or something out of a sci-fi movie."

Polestar is keen to highlight the use of sustainable material in the Precept. The vegan interior builds on that of the Polestar 2 with "high levels of recycled content". Light, strong flax-based natural composites developed by Bcomp reduce typical plastic usage by 80%. Recycled plastic bottles are used for the headlining, the carpets use nylon from reclaimed fishing nets and recycled cork

from the wine industry is employed for seat bolsters and headrests.

The Precept also features advanced autonomous functions via a roof-mounted lidar pod and marks the debut of a 15in infotainment screen that uses the latest Android OS and Google Assistant features.



A3 saloon will hit the UK in July with two petrols and one diesel

cylinder petrol. The 30 TFSI engine will be available as a 48V mild hybrid in dual-clutch guise. Two plug-in hybrid variants will go on sale further down the line.

Audi claims the new saloon has been tuned to be sporty and "a touch more precise" than the first-generation saloon. This is largely attributed to a new, centralised dynamic handling system that ensures optimal interaction between all components. Alongside the standard set-up, there is a sport suspension option and a suspension with adaptive dampers, which promises a breadth between highly comfortable roll motion and agile handling.

The most dramatic difference for Audi aficionados will be the A3 saloon's interior. As first seen in the Sportback, Audi has decreased the number of physical controls and ditched its familiar rotary controller in the centre console. For those models with a dual-clutch 'box, there is a new shifter sitting in a black gloss surround. Also in the minimalist centre console is a round, sensory volume

controller that reacts to circular finger movements.

There is a 10.25in digital instrument display and a 10.1in infotainment touchscreen is angled slightly towards the driver, while a new climate control unit below it replaces rotary dials with buttons.

The infotainment system, the third-generation MMI Navigation Plus, promises computer power 10 times better than that of its predecessor. Features include up to six user profiles, a wi-fi hotspot, online traffic information and improved natural voice control. For example, ask "Where's the nearest Italian restaurant?" and the sat-nav system will show those nearby. As well as Apple CarPlay and Android Auto, Amazon's Alexa voice assistant will become available soon after launch.

First deliveries are expected in July, but pricing has yet to be announced. In Germany, the new model starts from €27,700 (approximately £24,200) for the three-cylinder 30 TFSI.

RACHEL BURGESS



Concept previews a possible Tesla Model S rival

Renault pulls back from China

NON-ELECTRIC RENAULT passenger cars will no longer be sold in China after the brand withdraws from its joint venture with the Dongfeng Motor Group.

A press release has confirmed that all "Renault

brand-related activities" will be halted across China, although electric Renaults and small commercial vehicles will continue to be sold through other joint-venture operations.

Despite the market

withdrawal, the company claims "further development for Renault-brand passenger cars will be detailed later".

The decision was reportedly taken before the coronavirus took hold, but it's likely that the shutdown and market stagnation accelerated plans for Renault to abandon the loss-making joint venture. Dongfeng Renault Automotive Company (DRAC) built just 18,607 cars in 2019, despite having the capacity to make 110,000 a year.

The decision is also said to "more efficiently leverage" Renault's relationship with Nissan. Dongfeng will arrange positions within the wider group for joint-venture staff.



Kadjar's days in China are up as Renault ends Dongfeng tie-up

CADILLAC SALOONS TURN Hardcore

Cadillac will take on the super-saloon elite with faster and more track-focused Blackwing versions of the CT4-V and CT5-V hot saloons. The CT5-V Blackwing is believed to put out 650bhp from a supercharged V8. Neither car will be sold in the UK.



ZAGATO ASTONS NOW TO BE BUILT IN UK

Zagato's ultra-exclusive versions of the Aston Martin V12 Vantage will now be built in the UK, by R-Reformed in Warwick. Just 38 examples of the hand-built coupé and speedster Vantage V12 Zagato Heritage Twins will be made.





Hybrid V6 will first be used in 2022 Valhalla, then in 2023 Vanquish

Aston sets out its power plans

All-new hybridised V6 will replace AMG V8; Ford V12 production will be brought to UK

Aston Martin's hybridised V6 (News, 25 March) will rapidly be deployed across most of the marque's range once it has made its debut in the Valhalla supercar, Autocar has learned.

The all-new powerplant, due to enter production in 2022, will replace the Mercedes-AMG 4.0-litre V8 that's used in the Vantage, the lower reaches of the DB11 range and the soon-to-be-launched DBX SUV.

"Mercedes have made no secret of where their engine technology is moving to, and obviously we don't foresee four-cylinder engines in our Astons," CEO Andy Palmer told Autocar. "So we've got to make our own journey."

With integrated electrical assistance, the Aston Martin V6 should effectively be a modular replacement for the AMG V8, with Palmer confirming that it can be mated

to existing transmissions.

Just as important, it will make at least as much power as the AMG engine in these applications. "As you move on, you normally expect a power increase, not a decrease," Palmer said. "You're supposed to do that even with a smaller power unit, so there's no way our customers are going to expect to step backwards."

Aston Martin confirmed the new engine would be its most powerful yet when used in the Valhalla but that it would also be detuned and reconfigured to suit a variety of needs.

The British company has a long history of making straight sixes but has never done a V6 before. However, Palmer insists it will be possible to make sure it delivers a brand-appropriate experience. "The key is sound," he said. "Tuning the pipes to make it sound like an Aston.

"Obviously we can use

the hybrid system and the electric motor to fill in on torque, so you can compensate for the cylinder size with the electrical assistance.

"As long as it feels like a V8 and sounds majestic, I think it's a perfectly sensible way to go and a lot more sensible than a [four-cylinder] would be."

The V6 will be made in the UK by an as-yet-unspecified supplier. Autocar has been told that it definitely won't involve Ford's soon-to-close engine plant in Bridgend, despite its proximity to the new Aston Martin factory in St Athan.

We have also learned from insiders that Aston Martin is planning to move production of its twin-turbocharged 5.2-litre V12 engine to the UK (it's currently made at a Ford factory in Cologne, Germany), with the plan being to add an electrical element.

Aston Martin sold nearly

1800 V12-powered cars last year, and repatriating the powerplant to the UK shows a continued commitment to it.

"You can see in the longer term that it won't last," Palmer admitted, "but certainly over the next few years, we can continue to produce V12 engines, and we can make them more CO₂-friendly."

While the UK government's planned ban on the sale of all new petrol and diesel-fuelled cars - including hybrids - by 2035 will create big challenges, Palmer echoed McLaren boss Mike Flewitt by confirming his company won't stop developing part-combustion cars for other markets if demand is still there.

"The key point is that we make cars for the world, and the world hasn't said there isn't a future for hybrids or plug-in hybrids," said Palmer.

"If we were only selling to the UK it would be different,

but we're selling to a worldwide market where there's a variety of views on future technology and how it will be deployed."

We also asked Palmer about Aston Martin's withdrawal from the planned hypercar class in the World Endurance Championship after previously indicating that it would join.

"They changed the rules, nothing more, nothing less," he explained. "They allowed in IMSA vehicles. It was nothing to do with the state of the company, nothing to do with internal politics, nothing to do with anything other than that [Le Mans organiser] the ACO destroyed the business case.

"We were led to believe we were going to be racing hypercar against hypercar, but we didn't anticipate there would be a lower-cost way of racing a year later. The whole case just fell to pieces."

MIKE DUFF



Aston is committed to extending the life of its strong-selling V12

HOTTEST A3 SALOON TESTS WITH 394BHP

Audi's next-generation RS3 has been snapped testing in saloon form. The Mercedes-AMG CLA 45 S rival will take its 394bhp turbocharged 2.5-litre five-cylinder petrol engine from the new RS Q3 SUV. It's expected to enter production in early 2021.



SPY SHOT
AUDI RS3

MHEV sixes replace diesel V8 at Land Rover

LAND ROVER WILL introduce new mild-hybrid diesel engines to the Range Rover and Range Rover Sport in the coming months, effectively spelling the end for the V8 diesel engine, Autocar has learned.

After introducing its first mild-hybrid systems in four-cylinder engines for the new Discovery Sport and Range Rover Evoque last year, Land Rover will add the technology to two new six-cylinder diesel units. The firm hasn't officially confirmed details, however.

It's understood that a 296bhp 3.0-litre MHEV unit, badged D300, will be offered

on the HSE, HSE Dynamic and Autobiography Dynamic versions of the Range Rover Sport. The electrical system will give a moderate efficiency boost and aid smooth stop-start driving, thanks to an integrated starter-generator.

A more potent version of the same engine putting out



XF is set to go mild-hybrid too

345bhp (badged D350) will be available on higher-end trim levels, such as HST. This will effectively replace the 334bhp 4.4-litre diesel V8, which is built by Ford in Mexico and based on a 10-year-old design.

Oddly, information about the new unit has already been published by automotive data suppliers, despite Land Rover having not yet announced it.

The data reveals the D350 unit puts out 516lb ft of torque, giving the Range Rover Sport a 0-62mph time of 6.5sec and a top speed of 140mph. It also officially records 35.3mpg while emitting 210g/km of

CO₂. These figures are notably improved over the V8 diesel.

The same pair of engines will be added to the Range Rover, with the D350's 0-62mph time increasing to 7.1sec and its CO₂ emissions rising to 225g/km. Again, the D350 will only be available on pricier trims.

We can also expect either one or both of these engines to emerge at Land Rover's sister brand, Jaguar, with the upcoming facelifts of the XF and F-Pace. These cars were expected to be unveiled by now but have possibly been pushed back due to the pandemic.

LAWRENCE ALLAN



LAND ROVER SAYS a pick-up version of the Defender is "technically possible" on its D7x platform but that such a model isn't on its radar. The commercial pick-up truck market is very different to where the latest Defender is pitched and, unless such a vehicle were produced in much larger quantities and at lower prices than Land Rover plans, it could prove a distraction from the new Defender's market.

KIA WILL REDUCE sales of its Stinger fastback to 500 this year, down by half from 2019. Due to its 3.3-litre petrol V6 (now the sole engine offered), this is necessary to negate the EU's strict new emissions rules. Kia UK boss Paul Philpott said: "The Stinger will be an absolute halo model for us."



New engines are similarly powerful yet more efficient

Morgan will carefully modernise its styling

MORGAN IS OPEN to reinventing its design language, according to its styling boss. The British marque's roadsters have always featured a 1940s look, but Jonathan Wells said that needn't be the case forever.

"We have always believed that Morgan's design library is incredibly flexible and in no way constrained by the nostalgic influences we deploy in our cars," he told Autocar.

He cited the Aero range and the stillborn electric EV3 as examples. Both stretched the boundaries of Morgan's visual identity but didn't look amiss in its line-up because they still kept a high degree of purity.

"Every part of a Morgan should communicate its function and be there for a reason," Wells said.

Morgan will follow these strict guidelines as it creates newer-looking cars, which Autocar understands is a process already under way.

"Instead of moving so drastically from the 1940s and the 1950s to the 2020s and the 2030s, we're sort of migrating into the 1960s and the 1970s and maintaining

that distance [with the present]," Wells affirmed.

"We're trying to do so in a way that we don't generate a pastiche but maintain that authenticity and function."

Although he stopped short of revealing precisely what the company has in the pipeline or when it will expand its range, Wells told us that

the process of designing a car like the recently revealed all-new Plus Four starts by carefully studying the era to which it's a tribute. Simply copying and pasting an existing design wouldn't cut it.

"We try to imagine what these designers were inspired by," Wells said. "For example, the understanding of aerodynamics in the 1950s was very different than the understanding of aerodynamics today and, as a result, that was influencing the shape of those cars."

"We also try to understand the manufacturing techniques at the time and the cultural influences, which could be anything from interior design to fashion, and try to replicate that. We find it really exciting."

RONAN GLON

Plus Four still has its aesthetic roots in the '40s



VOLVO'S OFFER TO GIVE away a year's worth of free electricity to drivers of its plug-in hybrids is designed to show people how to get the best out of electrified cars, according to Olivier Loedel, the firm's business manager of electrification. "We're trying to encourage customers to drive more on electric power," Loedel said. "We can demonstrate they can do a daily commute on pure electric, for example."

OPEL AND VAUXHALL are now consistently profitable after three years of PSA ownership, following "20 years of burning €1 billion a year" under GM, according to PSA Europe boss Maxime Picat. The 6.5% margins now enjoyed by Opel beat those of most mainstream brands and some premium ones, Picat added, "showing what happens when you give people autonomy and empower them".

Aston not out of the woods yet

Despite a big cash injection from Lawrence Stroll, Aston Martin faces a tough future

It's an old political cliché that a week is a long time in politics. On the stock markets, however, just a few hours can turn a company's prospects upside down - as Aston Martin has just proven.

Ironically, as recently as 23 January, it was reported that analysts at Citigroup rated Aston as a 'high-risk, high-return' bet based on the potential of the DBX, targeting a future share price of £6.

Since Aston Martin Lagonda plc was floated on the stock market in October 2018, its launch share price of £19 has been in decline, dropping to £11.56 on 14 December 2018.

It had taken less than two months for the shares to lose around 40% of their value, although many analysts felt the initial launch price of the shares was over-enthusiastic.

By 18 January last year, things had picked up a little before continuing their downward journey. This was perhaps a little surprising, because Aston was reporting a generally successful 2018.

According to its accounts, the number of 'wholesale' cars sold for 2018 was 6441, up from 5098 in 2017. The company sold 1785 V12-engined cars and 4471 V8s. Sales in the US jumped 38% and Aston's revenue hit £1.1 billion, up 25%.

Excluding the 'specials' built by the company, the average selling price for its cars was £141,000. That's high, but perhaps not high enough considering Aston's incoming investment plans.

One surprise hiding in the accounts was that the cost of placing the company on the stock market was £136 million, helping to push annual profits down to just £68m.

On future product launches, the investor presentation was especially bullish. As well as

the DBX crossover, the line-up included two new mid-engined supercars - the Vanquish and Valhalla - as well as an electric SUV and electric saloon from Lagonda in 2021 and 2022.

On top of that ambitious schedule, in addition to 155 examples of the battery-powered Rapide E, Aston was promising the DB4 GT Zagato continuation model, the DB5 Goldfinger continuation and two versions of the Valkyrie hypercar.

Clearly, this programme - as well as the costs of setting up the St Athan factory for DBX production - was ambitious in the extreme, especially for such a small company.

The share price continued its overall descent during the first half of last year, dropping

to just £8.43 on 24 May before firming up to over £10 by July.

But a trading update and profit warning from the firm on 23 July put an end to any hopes of a recovery. Aston revealed it had experienced a 25% drop in sales between April and June last year, with falls of 22% in the UK and 28% across Europe and the Middle East. Shares plummeted by 26% in a single day.

On 31 July, Aston announced that it had lost £78m in the first half of 2019, in contrast to a £21m profit in the same period in 2018. By 5 August, the share price had cratered to just £4.54, then £3.99 by 31 October. However, some confidence returned to investors towards the end of the year, with the price

stuttering back up to £6.30 on 6 December.

That was the recent peak for the company, and one to which it is unlikely to return for quite some time. At the beginning of this year, Aston released its preliminary figure for the whole of 2019. Sales in the UK fell from 1798 to 1429 and in Europe from 1489 to 1074. Revenue went down 9%.

The rumour in the analyst world - one later confirmed by CEO Andy Palmer - was that Vantage sales had failed to hit the mark, which might explain the recent redesign. Even a rise in sales in the US couldn't prevent Aston's finances taking a beating. That ambitious new model programme was biting, with the company's debt leaping from £560m to £876m. Serious alarm bells rang and the company's cash position became incredibly precarious, making the planned roll-out of crucial models such as the DBX difficult.

Then came a rescue, of sorts, on 31 January, when billionaire Lawrence Stroll bought a

“
Stroll's investment pushed shares up to £4.98 on the day but it has been downhill all the way since then
”



Stroll is now Aston chairman

HOW ASTON MARTIN'S SHARE PRICE HAS PLUMMETED

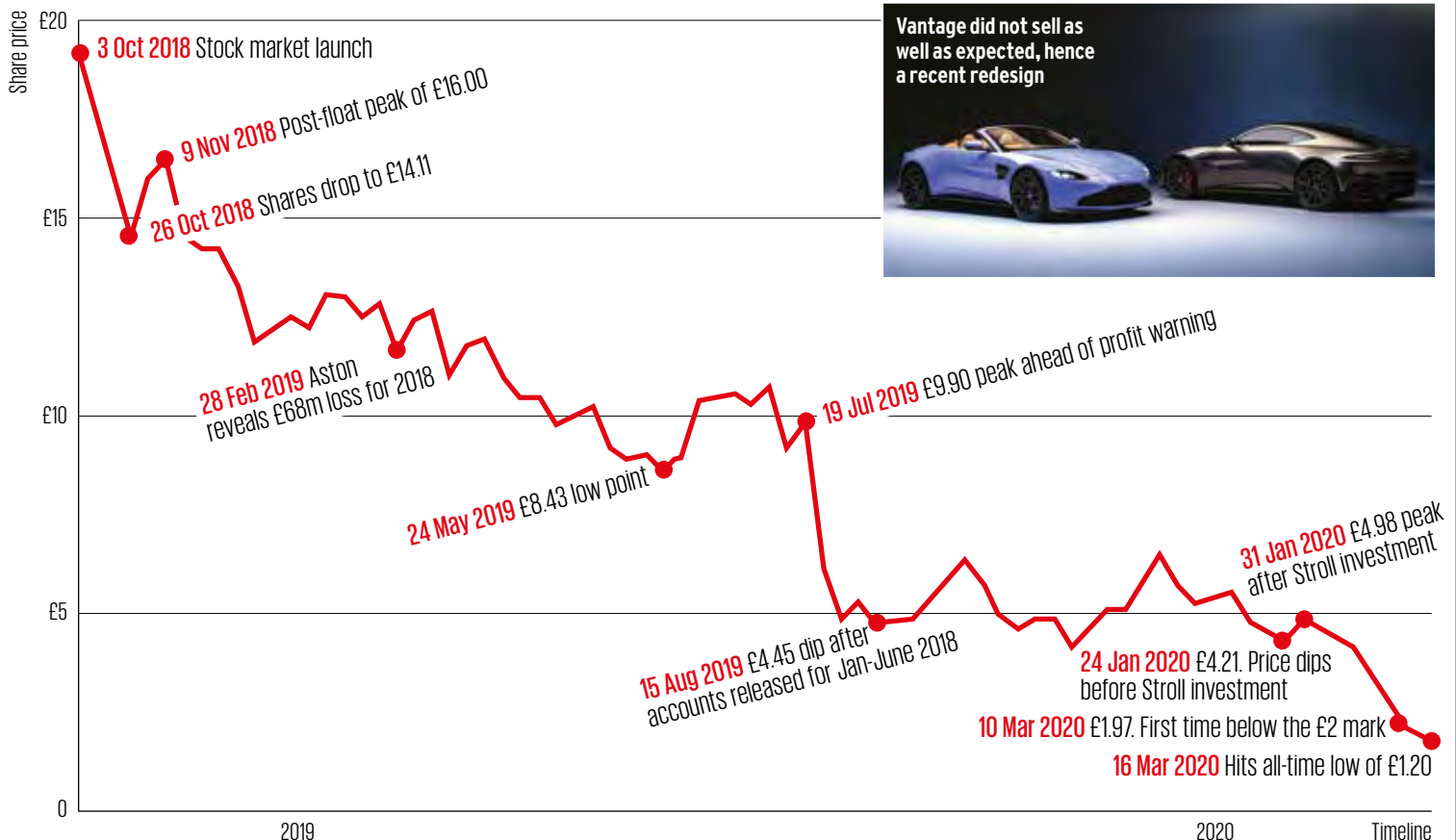



Stroll's investment will help to put DBX into showrooms this year

16.7% stake in the company for £182m, which was to be added to a £318m rights issue to give the company a £500m boost, get the DBX in showrooms and get the development programme for the new mid-engined cars well under way.

Stroll's plan, which made him chairman, confirmed the Valkyrie for this year, cancelled the Rapide E and pushed the relaunch of Lagonda back to 2025.

And then the coronavirus struck. Stroll took advantage of a well-placed clause in the original contract to renegotiate his offer, valuing the shares at £2.25 rather than the original £4 and taking a 25% stake. He also added an additional £25m to the original plan to give £55.5m in working capital in

order to tide Aston Martin over.

Stroll's new offer was, perhaps, based on the market price of £4.02 recorded on 30 January, and his investment pushed the shares up to £4.98. From there, though, it has been downhill all the way, as the world reacted to the spread of Covid-19.

After dipping as low as £1.20 during one day of trading, Aston's share price has ricocheted around under the £2 mark as day-traders took advantage of mini bounces.

But the value of Stroll's holding has already been halved. And with global car sales almost halting during March and revenue drying up, Aston's situation now, once again, looks critical.

HILTON HOLLOWAY



Lagonda's relaunch as a luxury EV marque is delayed until 2025

SHARE PRICE FALLS, 18.2.20-18.3.20



Renault down 53%



Nissan down 24%



FCA down 50%



Ford down 46%



Volkswagen Group down 49%



Toyota down 16%

UNDER THE SKIN
JESSE CROSSE

ALL THE GEARS, LOTS OF IDEAS: THE FUTURE OF TRANSMISSION TECH



Pure-electric and electrified power units are steadily taking over, but the gearbox is here to stay.

A GOOD ENGINE can make a car but a bad gearbox can ruin it. Those almost unfathomable concoctions of gears, bearings, shaft seals and complex mechanisms almost always make the difference between a great drive and a mediocre one.

The gearbox has been underestimated, then, playing second fiddle to the engine; always the bridesmaid, never the bride. But electrification has given automatic gearbox designers a golden opportunity to have a greater influence on the way a car performs by integrating a hybrid electric motor-generator inside the gearbox casing instead of attached to the engine.

Transmission giant ZF Friedrichshafen has been steadily building a portfolio of hybridised automatic transmissions for years, giving car makers a kind of modular toolkit of gearboxes to choose from. They work in the same way as their conventional counterparts, except for the addition of an electric motor in place of a torque converter.

The external package is pretty much the same too, so they're an easy fit. There's no variable-transmission effect and the drivability feels the same as a conventional car, but the powertrain can harvest energy through regenerative braking or boost torque to the driveline from the electric motor-generator like any other hybrid.

ZF's hybridised transmission range starts with a 20bhp 48V mild hybrid. This is followed by 54bhp and 121bhp full-hybrid, high-voltage versions and, at the top of the pile, a 134bhp full-hybrid version producing 295lb ft that can be used in both rear-wheel-drive and four-wheel-drive configurations.

The full-hybrid versions can decouple themselves from engines for driving in electric-only mode and incorporate electric pumps to keep the internal hydraulic mechanisms working when the engine is shut down for coasting or stop-start. More down-to-earth aspects of the gearboxes, such as torsional vibration dampers, can be tailored to suit an individual engine.

Gearboxes for pure EVs are much more

simple, with, in most cases, a single-speed reduction gear to step down the speed of the electric motor from around 12,000rpm to a more modest road wheel speed. Smaller, high-speed electric motors (over 20,000rpm), which produce less torque but save weight and space, are paired with a two-speed automatic gearbox. But even simple single-speed 'boxes have more to them than meets the eye. Just to confuse things, Volkswagen's ID 3 uses a two-stage single-speed gearbox.

The motor revs need to be reduced by times 10 at the wheels, and to do that with just two gears would mean the diameter of one of them would be too big to fit in the space available. Instead, the gearbox has two pairs of gears, the first reducing the revs from the motor by one stage and the second pair finishing the job. This is about as complicated as it gets for a single-speed reduction gearbox, and although they may be complex electronically, it's a neat illustration of how mechanically simple pure-electric drive systems are – and how some of the most familiar and basic components will always have a role to play.

LIFE IN THE OLD DOG

Sequential motorsport gearboxes like this older Ricardo design are 'dog' boxes without synchromesh, built for lightning-fast clutchless shifting. Gears are selected either via an electronic system and paddles or directly with a stick. Drivers can 'flat shift' if the gearbox is linked to the engine ECU, which kills torque for a split second to unload the gears so that ratios can be swapped in milliseconds.

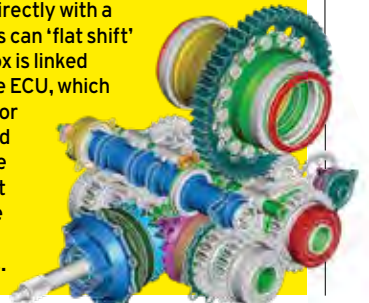

ID Buzz to be a new-age Touran

Volkswagen predicts its upcoming retro-look EV will revive flagging interest in MPVs



ID Buzz will arrive in 2022 and is tipped to have a 372-mile range

VW'S TWO BIG CHALLENGES

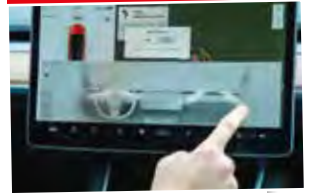

Catching up with Tesla on software and making people want to buy EVs will be Volkswagen's two biggest challenges over the next five years.

"We must move this company to [be] a more software-driven one," said R&D boss Frank Welsch. "Having good cars isn't enough. Online, we have to achieve upgradability, cloud management, data management and much more. Competitors such as Tesla are better at that, as they started earlier. We'll be on a par within a couple of years."

He also said EVs must be desired for being more suited to an owner's needs, not just for green reasons.

"I hope I can make people understand that EVs are the future," he said. "Buying them to help the environment can't be the reason. They have to buy them because they're better for their needs. If you compare the ID 3 with the Golf, for customers in urban areas the ID 3 is a better concept: cheaper total cost of ownership, more room, quieter and better acceleration."

The electric ID Buzz 'Microbus', due in 2022, will indirectly replace the Touran and reinvigorate the MPV segment through 'emotional' design, according to Volkswagen's board member for R&D, Frank Welsch.

Although the Mk7 Golf-based Touran is still on sale, the larger Sharan will be axed later this year and production of its Seat Alhambra sibling has just ceased (p6). It's expected that the Touran won't survive beyond the next couple of years as Volkswagen focuses on SUV demand and its huge investment in electric vehicles.

MPV ownership peaked in the noughties but has since waned considerably as consumers have favoured SUV styling. In the Touran's peak year in Europe, 2004, 191,414 examples were sold, compared

with 75,427 last year.

Name-checking the model as one of his two favourite to develop alongside the Golf GTI, Welsch said: "Some people would say the Touran is a boring car, but it has great efficiency, great value for money [and is] great for family."

He added: "Now we have other concepts [in place of MPVs], such as the Tiguan Allspace seven-seat SUV. And we have prepared for the next

generation with the ID family, including the ID Buzz, which we are developing now. These are the real successors of Touran.

"The Buzz has a lot of space. It's great-looking. The production version is even better than the concept. It's the best of the Touran."

Describing the ID Buzz as a new-generation MPV, Welsch said: "MPVs are not over, although demand is going down a little bit. They need better

design now. This is why the ID Buzz is quite emotional in design."

The ID Buzz, often described as a spiritual successor to the Microbus of 1950, sits on Volkswagen's electric-only MEB architecture and is expected to have a 372-mile range. Rear-wheel-drive and four-wheel-drive versions will be offered, delivering 268bhp and 369bhp respectively.

RACHEL BURGESS

Ageing Sharan will be axed at the end of this year



European sales of the Touran hit their peak back in 2004



Volkswagen has enough SUVs now, says R&D chief

THERE'S LITTLE ROOM left in Volkswagen's line-up for more SUVs, according to the firm's R&D boss, Frank Welsch.

VW has 14 SUVs in its range globally, up from two just a few years ago. Although Welsch wouldn't go so far as to confirm there would be no more, he said the brand has ample numbers for its need: "I don't think [the growth in SUVs] is over, but we have enough. We do not need 10 more. We have to take care.

We must have a portfolio that is efficient as a volume player. If we have too many models and sell 30,000 or 40,000 units a year, we can't make money. We will focus on the cars that can be successful."

SUVs confirmed for launch are in the electric ID family and include standard and coupé variants of the ID 4.

Welsch added that VW would cull models on its MQB platform "step by step". Models on that architecture

include the Arteon, Touran and Passat, but Welsch didn't detail which models will go.

With the launch of new models, in particular in its ID family, and the axing of others, Welsch predicted the number of cars offered will be similar.

"I don't think we'll have more cars than we have today. For SUVs, we are represented in every segment," he said.

Electric ID 4 SUV will be joined by a coupé version



Cheaper sports EV to follow Apex AP-0

APEX, THE FIRM behind the recently revealed £150,000 electric AP-0, will create a range of models over the next decade, going beyond sports cars and adding more practical four-seaters to its line-up.

While the firm is run by Hong Kong-based brothers Jason and Gary Yeung, its design, engineering and manufacturing base is in the UK. The AP-0 will be produced at a not-yet-built site in Woking, Surrey, that will be capable of producing 500 vehicles annually from 2022.

Following that, Jason Yeung said Apex plans to open a plant in China, which is likely to build its next model: a smaller, more affordable electric sports car.

Yeung said this model will cost less than £100,000 and that, although built in China, it will be designed and engineered in the UK, using the same EV platform as the AP-0.

The carbonfibre tub around which the AP-0 is built uses modular spaceframes that allow it to accommodate

differently sized models.

The AP-0 promises a WLTP range of 320 miles and the ability to charge up to 80% of battery capacity in less than 15 minutes, so expect any future electric models to at least match these figures.

Yeung said: "For now, our focus is the AP-0. But after that, we're aiming to have a factory in China where we would build a smaller sports EV. You can't find a reasonably priced sports EV at the moment."

His brother Gary Yeung added: "We're not trying to have a product similar to Tesla or other car makers. We're trying to make something different. At the AP-0's price level, we have a good-handling car but also one that's safe on road and eco-friendly."

Alongside a growing sports car range, the Yeung brothers revealed that another arm of the business will work on four-seat models, with the aim of the first arriving before 2030.

AP-0 will be built in Surrey, cheaper Apex cars in China



Audi eyes Green Hell with celebratory R8

AUDI IS PLANNING a hardcore version of the R8 dubbed the Green Hell. It last month filed a trademark claim for the name, which references the Nürburgring.

This suggests a track-focused version of the all-wheel-drive supercar is being developed as a run-out special, quite possibly with the production car lap record in mind.



Green Hell could outgun 602bhp R8 Performance

UNDER THE SKIN JESSE CROSSE

HOW BRITAIN MADE THE WORLD'S MOST POWER-DENSE EV MOTOR



3D-printing allows an intricate cooling channel to be created inside the motor

IT'S NO SECRET that less is more when it comes to engineering cars, especially where weight is concerned. But this concept also plays an important part in getting rid of lingering unwanted heat in powerplants.

The new Ampere motor-generator from British firm Equipmake is a small and light package that makes very high power. Its low weight, low-inertia components, less mass in which unwanted heat can be stored and superior liquid cooling all contribute to a power-to-weight ratio more than four times greater than that of existing EV motor tech.

The Ampere is made using additive manufacturing, which is the industrial term for 3D-printing using metal powder rather than, say, a plastic you might use in a home 3D-printer. Making parts by adding only the material needed rather than starting with a casting or chunk of metal and then machining bits off it has unique advantages.

Typical EV motors are classified as low-speed and deliver high torque from standstill. Small high-speed motors rely on their high revs to deliver their power, but getting the heat out of small, powerful packages quickly enough can be a problem.

The use of additive manufacturing techniques developed by specialist Hieta made it possible to design smaller, thin-walled heat exchangers for use inside the Ampere with a greater surface area through which to conduct heat to the liquid coolant. Elements of the motor usually made from multiple parts conjoined are formed in one far lighter piece, and these weight savings reduce inertia and allow much higher revs.

The Ampere is an internal permanent magnet spoke motor, which means that its magnets are embedded into the rotor like the spokes of a wheel. The usual approach is to laminate magnets to the rotor and use a retaining sleeve to stop them flying off, but all of that adds weight.

Spoke design maximises the effect of the magnetic flux and enables the coolant to get closer to the magnets than is possible in conventional motors. Cooler magnets are more powerful than hot magnets, so less of

the expensive magnetic material is needed and efficiency is increased.

The new additive manufacturing techniques have raised Equipmake's spoke motor design to the next level, hence the impressive power-to-weight ratio of 295bhp at 30,000rpm from just 10kg. Equipmake claims this makes it the most power-dense motor in the world.

The power of motors is usually quoted in two ways. Continuous is what it can produce all day without overheating, while peak is the most that it can manage for short bursts. Because its internal cooling is so effective, the Ampere can run closer to its limits for much longer than conventional motors.

Transferring technology from the track to the road is a much-vaunted, if sometimes tenuous, concept used by manufacturers to justify the huge expenditure. Equipmake was the supplier of the high-speed flywheel concept used by Williams in Formula 1, so in this case, the lessons learned from race engineering do actually have a good chance of finding their way into mainstream cars.

Equipmake and Hieta have used 3D-printing to create the coolest EV motor on the planet.

YOUR CAR MAY BE PRINTED

Mainstream car manufacturers are also now using additive manufacturing. Pretty much every metal that can be welded, including tool steel, aluminium and titanium, can be 3D-printed. Below is a conventional Audi engine mount on the left compared with a 3D-printed alternative on the right.





Mercedes assault on batteries

Firm is researching multiple technologies to improve range and sustainability of EVs

Radical environmentally friendly organic batteries are a “very promising technology” being evaluated by Mercedes-Benz for future use in road cars.

This idea was previewed on the future-gazing Mercedes Vision AVTR concept car that was unveiled earlier this year. Although that was designed as a preview of what the Mercedes S-Class could look like in the 22nd century, the battery technology under its skin is far closer to reality.

Organic batteries are made from graphene-based organic-cell chemistry with a water-based electrolyte. That means they don’t use any rare or toxic materials or metals, making them entirely recyclable

through composting. Early testing shows they also offer both a high energy density and quick-charging capability.

Andreas Hintennach, senior manager of battery research at Mercedes, said: “It’s a very promising technology. I’ve already seen it working in laboratories, where the results look really good, but we don’t see that it’s close to being used in production technology for now. It’s around 15-20 years away.”

Mercedes has set itself a goal of becoming entirely carbon-neutral by 2039. To this end, it’s researching a number of technologies to reduce the environmental impact of battery production - particularly by cutting down

the use of controversial materials such as cobalt and lithium. All of the firm’s current electric vehicles use lithium ion batteries.

Mercedes is working to improve the efficiency of lithium ion batteries -

Hintennach estimates that range could still be boosted by up to 25% - while evaluating a number of future technologies that it aims to introduce within the next five-15 years.

That includes solid-state batteries, but while Hintennach

said this technology “opens a lot of doors and windows”, he cautioned that “it’s not a magic solution”. He added: “Solid state adds lots of positive aspects. It’s not a miracle but would be a huge step forward.”

Hintennach said that a major current problem with solid-state batteries is long charging times, making them unsuitable for road cars. Mercedes is aiming to introduce them into production in an eCitaro bus in the second half of this decade.

Other technologies under investigation include lithium-metal anodes, lithium-sulphur batteries and lithium-oxygen batteries. Hintennach said that all offer different benefits and drawbacks in terms of efficiency, density and weight.



Mercedes aims to introduce solid-state batteries in its electric bus

Synthetic fuel not seen as viable option by Mercedes

THE USE OF synthetic fuels in cars isn’t viable in the mid-term, according to Mercedes research and development boss Markus Schäfer, who said the firm is focusing investment on electrifying its cars.

While some manufacturers - such as Bentley, Mazda, McLaren and Volkswagen - are seriously researching

synthetic fuels as a credible alternative to petrol and diesel as well as newer and cleaner alternatives, Schäfer said Mercedes won’t go that way.

“We have made a clear decision that our way will be electric first,” he said. “When we develop new platforms, we think electric first. We have to watch regulations

and customer behaviour, but this will be our main road.”

Explaining his reservations concerning synthetic fuels, Schäfer said: “If you have an abundance of energy, the best use is to put it directly into a battery. To transform green energy into an e-fuel is a process where you lose a lot of efficiency.

“If there were more clean energies available, then the first customers would probably be in the aviation industry. Far, far later - I don’t see this in the next 10 years - will come the car industry.”

Mazda’s research on the topic is around recyclable liquid fuels made from microalgae, while McLaren

is looking at a CO₂-neutral synthetic fuel to power its V8.

Audi got as far as producing its own synthetic petrol and diesel for testing in 2018, while Volkswagen’s technical chief recently said that such fuels will extend the life of the combustion engine, despite the VW Group’s huge investment in electrification.

Vision AVTR concept introduced idea of organic batteries



He noted that different battery types would likely be used in different vehicles, with lithium-sulphur, which is lighter than lithium ion, potentially allowing use of smaller packs. Researchers elsewhere in the industry have claimed lithium-sulphur could be one of the closest to commercialisation.

When asked if there's a risk in pursuing multiple technologies simultaneously, Hintennach said: "It is challenging, but you need novel ideas. We need to be very focused on the future."

"You do risk inefficiency by looking at multiple options, and not all will make it to market, but if you didn't take risks in R&D by backing multiple horses, then you could end up losing. We're also keeping the pipeline open for the future."

JAMES ATTWOOD

A BATTERY OF FUTURE TECHNOLOGY

Lithium-metal and silicon
What is it?

Replaces some carbon elements in the battery with silicon, helping lower CO₂ and costs. Also non-toxic, but safety is still being worked on. Could boost range by 20-30%.

How far off?
Five years.

Solid state
What is it?

Uses solid electrodes in place of the liquid ones in lithium ion batteries. Safe and versatile but has low energy density and is slow to charge. Could boost range by 35-40%.

How far off?
Five years.

Lithium-sulphur
What is it?

A low-cost industrial waste product that is pure, easy to recycle and more abundant than cobalt, but energy density and durability are challenges. Could boost range by 40-50%.

How far off?
10 years.

Lithium-oxygen
What is it?

Uses air to react with lithium, working in similar fashion to fuel cells. Has strong energy density, but lifetime and durability are issues. Could boost range by 50%.

How far off?
15 years.



Nissan Ariya is close to reality

THE NISSAN ARIYA concept previews the long-mooted 'Leaf SUV', which is expected to arrive by 2022. Revealed at the Tokyo motor show late last year, the Ariya was described by chief designer Giovanni Arroba as a "realistic vision of our future". He added: "It's not a blue-sky concept car, so everything there is tangible to bring to the market in the hopefully near future."

Explaining that Nissan had pioneered the crossover segment, first with the Qashqai and then with the Juke, Arroba said: "We've always been

on the cutting edge of introducing new segments. In this case, we wanted to have an electric crossover which is beautiful, functional

and realistic for now."

We discussed some highlights of the Ariya with Arroba below.

RACHEL BURGESS



● Nissan has followed its rivals by spelling its brand name across the taillight rather than using its logo. The word is integrated into the horizontal light blade, which Arroba described as "very simple yet very iconic". Expect to see it on a Nissan production car soon.



When Nissan launched the Leaf in 2010, it used blue accents to highlight the car's eco credentials. In the Ariya, this has been replaced with copper. Arroba explained: "This moves into the future of how we represent EVs. Copper is a conductor of electricity. In the past, we've used blue to represent EVs, but copper showcases the premium EV design here."

The Ariya's roomy interior is thanks to Nissan's new EVP platform; for example, it has allowed the air-con unit to be moved from in the centre console to under the bonnet. It's a dramatic step up from the Leaf, but Arroba said none of it is unattainable for production. While there's a glass panel that leads from the digital instruments to the touchscreen, switches and haptic touch-sensitive icons remain. "Everything we have done is for approachability," said Arroba.



● The Ariya represents a new design direction for Nissan overall. Arroba explained: "The front is a vision of our brand identity electrified. We have super-thin LED projector headlamps and there's no traditional grille; instead, we have a shield that packages radar and cameras. We want to represent electric as beautiful. We don't want to, through certain shapes or form, say 'hey look!'. It's not meant to walk into a room blaring to be different."

● Arroba admits that the 21in wheels are there for design purposes so are unlikely to make production. "We wanted to have a strong proportion and stance," he said. However, the aerodynamic design could well make it to the final model. The five-spoke wheels have milled-and-machined lightweight alloys beneath and aerodynamic blades shielding the wheels and bolts to allow air to pass by without too much disruption.

● One might expect to see rear-view cameras in place of side mirrors here, as is becoming common on the latest EVs, such as the Audi E-tron and Honda E. However, Arroba remains unconvinced. "We wanted to showcase a tangible reality that's coming upon us quickly," he said. "We didn't want to showcase technology which isn't fully regulated in all regions. I've experienced cars with camera mirrors and the usability isn't as seamless as with a mirror."



Mercedes' €10bn electrification is now in full swing

Big screens, such as in Tesla's cars, are regarded as safer



Are touchscreens a good thing?

Safety concerns about in-car touchscreens are giving rise to new developments

It's hard to find a new car with a dashboard that isn't dominated by a large infotainment touchscreen - increasingly at the expense of physical buttons and dials. Tesla may still be the most extreme proponent, but the trend is reflected across the whole industry.

The growing size of touchscreens is linked directly to their increasing use in all aspects of society. Melanie Limmer, the electronics boss for the new Audi A3, said the decision to remove some physical buttons from that car was because "more and more people are getting into touch functions with smartphones".

Although many car infotainment screens retain physical controls as well, an increasing number don't - and the rise of touchscreen-only interfaces has led to questions about how safe they are. There are concerns that large screens can cause a distraction and that, without the tactile response of a physical button to assure users they've selected the right option, drivers are more inclined to look away from the road to operate them.

Still, the growth in the size of touchscreens is a boost for

safety, according to Matthew Avery, director of research at leading UK automotive safety body Thatcham Research.

"Large infotainment screens are not necessarily an issue, because they allow for bigger icons and less crowded displays," he said. "Small screens with fiddly icons are a greater concern."

Avery also said the latency of such systems is crucial: "Screens must be as responsive to touch as you would expect a smartphone to be. Clarity and user interface commonality across vehicles is also fundamental, allowing drivers to more instantly recognise the icon they intend to press."

Avery cites the Apple CarPlay and Android Auto smartphone mirroring systems as key to that, because they work the same across every model of car. They also replace any need for drivers to use smartphones while driving.

The government is currently working to close loopholes that have enabled some drivers to escape penalties for using smartphones for functions other than making phone calls while driving. But some of the same concerns about such distractions could apply

to touchscreens. Highways England boss Jim O'Sullivan has said: "We don't like them from a safety perspective."

But touchscreens in cars and smartphones aren't directly comparable, of course. When considering further limitations on mobile phone usage while driving, the Transport Select Committee ruled out banning hands-free calls. That was despite research suggesting the risks were largely down to the cognitive demands they place on a driver "engaging with someone who is not in their shared environment" rather than the actual operation of the smartphone.

For those involved in touchscreen development, the systems aren't just styled on smartphones: they're a way of supplementing them.

"Safety comes in many forms," said Google's Harris Ramis, who works on the new Android-based touchscreen operating system, a version of which will be used in all future Volvo and Polestar models. "Today, people pull out their phones and use them while driving anyway, so when we started thinking about safety, we did so from the perspective of ensuring they have access to the services they want that are built for in-car use, to ensure they leave their phones where they need to be."

Ramis referred to that approach as "driver distraction optimised". Effectively, this is recognising that people want to use the phone system or music services on their smartphones and finding ways to offer that as safely as possible via a car's

infotainment system. "We spent a lot of time working to ensure the system is built for use while driving, so it doesn't distract," said Ramis.

To ensure that, the new Volvo Android system - which will be seen first on the forthcoming XC40 Recharge P8 EV - is a fixed template design, with the basic controls required to be in the same place across all apps, ensuring user familiarity. That applies even to the 'third-party' apps that will be offered on Android systems.

Another key function offered by the new Volvo system is voice control, the increasing use of which could remove the need to use a touchscreen or any physical controls. Voice control has been widely in use across car brands for years, with the Volkswagen Group, Mercedes-Benz and BMW all offering their own versions.

Ödgård Andersson, Volvo's digital boss, said: "Voice commands make total sense when you're driving." Thatcham's Avery agreed: "It brings clear benefits in keeping the driver's eyes on the road."

But he also said: "Functions like this are often built in some years ahead of a model hitting the road and are therefore



Volvo has teamed up with Google to create a safer in-car set-up



Audi's new A3 has fewer buttons and more touchscreen reliance



Voice control is becoming increasingly receptive to natural speech

behind the development curve of [Apple] Siri or [Amazon] Alexa. Where the voice control fails to recognise what the driver is saying, the safety benefits are lost."

Andersson said that having access to Google Assistant voice control is "a key thing we're very excited about" with the partnership.

The Google system is being continually developed based on real-world feedback from its use in other smartphone and electronics functions and works with multiple languages and accents. Andersson claimed that "it's well above anything that's in any car right now". She added: "It enables

you to speak in a much more natural way, which is a safety feature from our perspective."

The hope is that such improvements might win over people yet to be convinced by voice control. But it's also about choice: giving drivers multiple ways to control a car so they can use whichever is the most comfortable to them – which will likely be the safest.

It's clear from looking inside any concept car that, like them or not, touchscreens are increasingly going to dominate car controls. It reflects demand. The key is ensuring technology developments make them ever safer.

JAMES ATTWOOD

WHY HONDA IS BRINGING BACK DIALS

Not every car maker is removing physical controls from dashboards: Honda has returned to some analogue controls in the new Jazz as a result of customer feedback.

The Japanese company has decided to reintroduce heating and air-conditioning controls via a dial rather than a touchscreen, as in the

previous-generation Jazz.

Takeki Tanaka, the car's project leader, said: "We wanted to minimise driver disruption for operation, in particular for the heater and air conditioning.

"We changed it from touchscreen to dial operation, as we received customer feedback that it was difficult to operate intuitively. You had to look at the screen to change the heater setting. Therefore we changed it so one can operate it without looking, giving more confidence while driving."



UNDER THE SKIN JESSE CROSSE

WHAT THIS PIC REVEALS ABOUT ASTON'S NEW TWIN-TURBO V6



Aston's TM01 is no revolution, but the devil is in the detail.

ASTON MARTIN'S NEW 'hot vee', dry-sump 'TM01' V6 engine, so named because the turbos lie in the vee of the engine, looks as exciting on paper as it probably will be in the flesh. Although Aston isn't disclosing a huge amount of detail at this stage, the picture of it shown above reveals a lot.

Starting at the bottom, there's that sump. 'Dry' sump is a bit of a contradiction in terms, because sumps on engines store oil and dry sumps are designed to do the opposite. Instead of a large, deep sump full of engine oil, the dry sump is reduced to a shallow pan and gives two advantages.

The main one is that oil is pumped around the engine from a separate tank, so there's no chance of the oil pick-up collecting air instead of oil during hard cornering, braking and acceleration. The second is that a shallow pan in place of a deep sump means the engine can sit low in the chassis, lowering the car's centre of gravity.

Bottom left looks like the dry sump pump. The difference between this and a standard oil pump is that it scavenges oil as well as pumping it, and it scavenges faster than it pumps, so the pan remains quite dry – hence the name. If it didn't, the engine would drown in its own oil.

The Y-shaped casing on the front of the engine is likely to cover chains, rather than belts, taking drive from the crankshaft up to the four camshafts.

The pair of black circular covers at the top of each Y form part of the variable cam timing mechanism and give away the position of each camshaft. Above that are the air compressors of the twin BorgWarner turbos. On top of each one, a black electronic control unit opens and closes the turbo's wastegate on the 'hot side' of the turbo, towards the rear of the engine, via a rod.

The two large ports at the top are the turbo air intakes and the lower pair are the exits for the pressurised air. Hoses will take the intake air from the lower two ports via intercoolers to the two throttle bodies on the

front of each plenum chamber tucked under each cylinder bank. On this prototype, they're made by the Italian firm Dellorto, which was famous for its carburettors back in the day.

The three black blocks on top of the right-hand side of the engine are coil packs, one for each spark plug. In this configuration at least, the TM01 appears to have both direct and port fuel injection – an idea pioneered by Toyota. To the right is a fuel rail (pipe) for delivering petrol to three port injectors, their black electrical connectors peeking out above the rail. Three more direct injector connectors are visible just below each coil pack for delivering atomised fuel directly into the combustion chamber.

The combination of the two gives more scope for blending the torque of the engine at different revs and loads with the hybrid

BATTERY TESTING GETS REAL

The testing of EV batteries and being able to simulate real-life drive cycles in the laboratory is an important part of improving the breed, and Mahle Powertrain has just opened a new facility to do exactly that. The firm is famous among other things for making components such as forged pistons for high-performance engines.





Platform has flat floor. Wheel modules control main functions

Israeli firm 'reinvents' EV base

REE's radical EV tech enables a 2.7m-long five-seat robotaxi and much more besides

Israel-based start-up REE has designed a new electric vehicle platform with modular corner and wheel assemblies that, it says, allows more freedom of design and the fitment of more body configurations than is possible on current EV architectures.

REE's platform can incorporate a totally flat floor while the motor, suspension, steering and braking - all of which are by-wire systems - are all handled by individual wheel modules. There's an ECU at each corner and one within the chassis itself. The system is scalable for anything from small delivery vans to large commercial vehicles.

Speaking to Autocar from Tel Aviv, REE co-founder and CEO Daniel Barel said: "A V6 internal combustion engine [ICE] platform and Volkswagen's

MEB [electric architecture] are more or less the same. It's still a three-box chassis configuration. They've taken the ICE and moved it into an electric motor, and the centre is a skateboard chassis, but it's far from a skateboard. Tesla's is the same and Jaguar Land Rover's is the same - and that didn't make any sense to us."

REE's corner modules have the motor and software attached to the chassis end of the suspension, so this isn't a motor-in-wheel design, which would have a heavier unsprung mass and the ride and handling disadvantages that entails.

REE says a corner module can be removed and replaced in 18 minutes, which would give real gains in downtime and maintenance costs for commercial vehicles.

The architecture, which

can have raised wheel arches by using horizontally located springs and smaller wheels, has already been showcased by Hino Motors, Toyota's commercial vehicle division, with which it has a partnership, in a six-wheel configuration.

"Everything you can see there is what we do for them - the motor, the braking, the suspension, the drivetrain, everything. You can imagine the depth of due diligence we had to go through before they trusted us," said Barel. "I can't think of any other manufacturer that is so 100% involved in the major future of any OEM [original equipment manufacturer]."

REE has partnered with other OEMs and tier-one suppliers (T1s), including Mitsubishi Corporation, American Axle and Musashi, one of the world's

largest gear manufacturers. With new market entrants, too - in the autonomous and last-mile delivery segments - Barel claims there's interest from plenty of market segments.

"One is new autonomous delivery vehicles," Barel said, "which is small, slow vehicles. Some countries are more open to that than others. Those have been permitted to go on the road in the US already, and soon in Japan."

"Shuttles are an interesting business for us as well. And a robotaxi [an autonomous short-haul car] we're building with a partner is 2.5cm longer than a Smart car and seats five comfortably."

That would put an autonomous taxi at just 2.7m long but gains in usable space exist if REE's platform can use the full length of the platform.

Instead of having a large manufacturing base of its own, REE says it has identified partner-company factories that have spare capacity, which saves it bigger capital expenditure costs.

"We have unique partnerships with the world's biggest T1s," said Barel. "They're our investors and shareholders. We do all the research and development and then, like any other OEM, we send it to production." REE says it can build components in more than 300 plants worldwide.

Barel said the focus isn't solely on autonomous or commercial vehicles: "There will be a steering wheel. There is a car today that is by-wire and you can drive it. We're agnostic to whether it's autonomous or not. You can put anything you want on top."

The company is also open-minded about which badging its platform gets. "We want to be the 'Intel inside' of it," Barel said.

"For the first time in a century, you don't know how cars are going to look in five, 10, 15 years from now," Barel said. "It's a moving target, so how do you hit one? You make something that is completely different to anything else."

MATT PRIOR

REE is behind the Toyota-owned Hino Motors six-wheeler



VW Group's MEB platform is far less flexible, says REE



Vauxhall boss tips next big thing in retail

VAUXHALL BOSS STEPHEN Norman believes the UK's coronavirus lockdown is encouraging car buyers to embrace a new phone-based direct sales system his company is rushing to put in place – and he's confident it will remain effective long after business returns to normal.

Norman is so passionate about the new project that he plans to spend two hours a day personally answering phone calls from potential customers. The firm has about 12,000 cars in the pipeline between production line and dealer, a figure he called "unusually low".

"Even when we're clear of the epidemic, I believe retailing will never go back to the way it was," said Norman. "I expect car buyers to keep doing what we're encouraging them to do now: phone the company, get a response from a human being who can guide them through the process, then carry on their business through the retail network in the usual way."

Norman said this new trend won't make dealers irrelevant but is likely to threaten the cost base of what he termed "gin palace" dealerships.

He said the eventual return to normal social values will put extra focus on what he claimed is a recent, society-wide over-consumption of premium products and values. "Before the epidemic, this trend had arrived in the food and clothing industries," he said. "I think it's coming to the car industry."

For this reason, Norman forecasts increasing relevance for his bold Great Brit Plan, the Vauxhall ad campaign featuring the post-Brexit slogan 'New Rules Britannia', which was just starting to benefit Vauxhall sales when the pandemic hit.

"Our plan could prove even more relevant than before. I certainly expect it still to be working through next year," he said. "We have to be very careful not to take the fun out of car purchase. It'd be a disaster if we let it become boring."



Norman: "Retailing will never go back to the way it was"

Air pollution could increase Covid-19 risk

AREAS WITH HIGHER local air pollution could be seeing higher rates of Covid-19 infections, according to Italian research. University of Bologna and Bari researchers claim it is possible that virus cells are latching on to airborne soot particles and remaining in the air for longer and travelling further than areas with less pollution. Although it's just a theory, the correlation tallies with the rate of infection experienced in places such as Wuhan in China, the Lombardy

region of Italy and cities such as London and New York. The theory is countered by some medical quarters that claim it is the effects of the pollution itself (respiratory diseases, hypertension, weakened immune systems) that are leaving people in affected areas more vulnerable to the infection. Other theories suggest the pollution interferes with things that would normally kill the virus, including protecting the virus from ultraviolet light.

UNDER
THE SKIN
JESSE CROSSE

HOW A 100-YEAR-OLD TECHNOLOGY STILL UNDERPINS MODERN ENGINES



Multiple inlet and exhaust valves improve drivability and performance.

FOUR-VALVES-PER-cylinder engines are the norm these days and the cylinder head combustion chambers of Aston Martin's TM01 engine we examined here last week look much like they always have. Petrolheads generally accept that four valves per cylinder – usually opened by twin cams, one for inlet and one for exhaust – is better than two, but what's the advantage? Engines rely on getting as much air into each cylinder as possible to produce power. Surprisingly, using two large valves, one to let exhaust out and a larger inlet valve for letting air and fuel in, isn't the best way to do that. You can think of a valve in a typical engine as a disc attached to the end of a stick that seals a port in the combustion chamber of the cylinder head. When the valve opens, its disc-like head describes the walls of an invisible cylinder known as the 'curtain area'. It's this area that the air will flow through to enter the engine, or in the case of exhaust valves, for gases to get out.

Do the sums and the numbers surprisingly reveal that two smaller valves – say, half the size of a single valve – allow more air to flow into the engine? The power an engine makes is derived from the torque generated in each combustion cycle, so up to a point, the faster an engine revs, the more power it produces. But at high revs, it becomes harder to get enough air in quickly enough and that's where two inlet valves have an advantage over one.

Multiple valves also give designers more scope to improve swirl in the combustion chamber, needed for fuel-air mixing, and the smaller components are lighter, which is an advantage when they have to move faster. The downsides are that four-valve layouts require many more parts and more complex machining than two-valve, and back in the day that restricted use of the design to more exotic engines.

The idea isn't new, first appearing in cars in the early 1900s. Honda split the difference in the 1970s with the Civic's three-valve-per-cylinder engines – two inlet

valves per cylinder and one exhaust – giving most of the advantage of four valves, but using only one camshaft to keep cost down.

The main difference more recently has come with direct injection and the insertion of an injector into each combustion chamber as well as a spark plug. With direct-injection engines, more of the combustion chamber lies in the crown of the piston to generate maximum swirl and the best air-fuel mixing, but the design of the inlet ports of the cylinder head still matter.

So while all modern engines are boosted usually by turbochargers, the fundamentals of how an engine breathes still play an important role. Aston says it's allowing for various injection techniques for the TM01, including port injection. That could mean a version with direct injection only, rather than the combined direct and port injection we've seen in pictures of the prototype.

BEYOND BAFFLING

The latest performance exhaust silencers often incorporate a lot more than a few baffles. The new Chevrolet 'cold end' exhaust designed for the 2020 Corvette Stingray incorporates up to four Tenneco electronic valves to work in conjunction with the engine's fuel management system and cylinder deactivation system, as well as modifying the exhaust note.



First high-riding Ferrari is scheduled for 2022



AUTOCAR IMAGE

Roma coupé was one of five Ferraris to come out in 2019



Two new Ferraris this year

Major range expansion set to continue despite Covid-19 disruption

Ferrari plans to reveal two new models this year, and its commercial chief has hinted they will continue the push into new markets. The firm launched five new models in 2019, including the F8 Tributo, SF90 Stradale and Roma, as part of a major range expansion that's set to include 15 cars in a five-year window. At the unveiling of the Roma, Enrico Galliera said 2020 would be "a year of consolidation" to support those launches. But when asked more recently if that meant Ferrari won't unveil any new cars this year, he told Autocar: "We're always planning to do something more, and we intend to make some news. We will launch two new models by the end of the year." Galliera was speaking before the Covid-19 pandemic forced Ferrari to suspend production at its Maranello factory, and the ongoing threat could lead to the unveilings being delayed. Ferrari is understood to be amending its plans for the rest of this year before an investors'

presentation in May but, with production slated to resume this month (see below), it could still continue with its expansion. According to Galliera, the new cars were scheduled to be revealed in the second half

of the year before the closure. While he wouldn't offer any details about them, he did hint that they will continue Ferrari's range expansion, saying: "We'll keep looking at new, untapped markets."

Regarding 2020, Galliera said: "We need to consolidate the launch of our five products from last year but, while doing that, we don't stop looking for opportunities to grow as a company and business."

MARANELLO SET TO REOPEN NEXT WEEK

Ferrari is aiming to resume production at its Maranello factory on 14 April after a month-long shutdown caused by the coronavirus. Production was halted on 15 March, largely due to supply chain issues and for workers' safety. Maranello is located in Emilia-Romagna, which borders Lombardy, the region worst hit by the Covid-19 pandemic in Italy. Ferrari has worked to secure its supply chain and is understood to have the backing of trade unions. Autocar understands that Ferrari hasn't received an abnormal number of order

cancellations so is having to evaluate ways to make up for the production shortfall, likely by adding a second shift temporarily or working on Saturdays. Ferrari continued paying its employees in full during the shutdown. It will give a further update on how its business and 2020 plans have been affected during an earnings call on 4 May.



When asked what segments Ferrari is looking at, beyond the Purosangue SUV that's due in 2022, Galliera said: "Potentially every segment is of interest to us, with the caveat that Ferrari is in the luxury sports car market. "We can enter every market in which we can deliver a car that meets our position as a luxury car firm. We have certain limitations connected to the [sportiness] of the car: Ferrari is a sports car manufacturer. "When we look at new segments, we have to keep in mind the soul and positioning of the Ferrari brand, and that's our only limitation. There are some natural segments, such as sports and GT cars, but we can look to others as long as they're consistent with our heritage." **JAMES ATTWOOD**

HOW IMPORTANT ARE performance models to the Volkswagen Golf's success? Well, according to the firm, the hot variants (the GTI, GTD, GTE and R) made up around 40% of sales of the Mk7 model in the UK. The GTD diesel was the most popular of those, but many buyers of the Mk8 Golf are expected to migrate from that to the GTE petrol-electric plug-in hybrid.

IT HASN'T BEEN around for long, but Cupra's early sales success has proved its critics wrong, according to new CEO Wayne Griffiths. "At the time, there were a lot of people around who had their doubts," he said at the launch of the new



Cupra Leon. "We've sold 40,000 cars globally since launching the brand, with 25,000 of those in 2019. That's 70% up on the year before." In two years, Cupra has become Seat's most profitable business unit.

A KEY REASON Volvo partnered with Google to create a new infotainment operating system was to ensure its electrified cars could offer Google Maps. Olivier Loedel, Volvo's electrification business manager, said: "It's not about range anxiety any more, it's charging anxiety, and Google Maps gives detailed information on charging points."

THERE'S STILL A future for saloons, according to Kia UK boss Paul Philpott, despite sales of the Optima and all but the GT S version of the Stinger being stopped recently. Philpott said that if electrified models arrive that could help emissions targets be met, Kia would consider selling them here.

Aston still needs cash

ASTON MARTIN MAY still not have enough working capital to sustain it for the next year, despite the recent £536 million fundraising round and rights issue led by billionaire Lawrence Stroll's consortium. Stroll, who will take over as executive chairman of the car maker on 20 April, will rebrand his Racing Point F1 team Aston Martin F1 for the 2021 season. The injection will allow DBX

production to start as soon as the St Athan factory returns to normality. First deliveries are set for the summer if the supply chain functions as anticipated. More than 2000 DBX orders have been taken already, plus there's strong early demand for the new Vantage Roadster. However, the pandemic has still had a big impact on Aston, with its share price hitting a new low of £1.04 on 1 April.



First Aston Martin SUV is absolutely crucial to the brand's future

UNDER
THE SKIN
JESSE CROSSE

BRITISH FIRM FINDS A WAY FOR E-BOOSTERS TO REPLACE TURBOS



New electronic control system could consign turbochargers to history.

WHEN THE FIRST prototype e-boosters came on the scene a few years ago, back-to-back comparisons with conventional turbochargers swiftly revealed what an improvement they made to the response of large-capacity diesels. Until this point, the compressors, driven by an electric motor rather than exhaust gas, have only been used in short bursts before a conventional exhaust-driven turbocharger system takes over. Now, Aeristech, based in Leamington Spa, has come up with a new e-booster that can be used full time, doing away with exhaust-driven turbochargers altogether.

A turbocharger is driven by the energy released from hot, expanding exhaust gases. The harder the engine is working, the more energy there is and the quicker the turbocharger responds. When the engine isn't working so hard, there's less energy in the exhaust and turbocharger response gets laggy. Diesels are more thermally efficient than petrol engines, so more of the fuel is converted to mechanical energy rather than heat and the exhaust releases less energy. So when a diesel is loafing around, its turbocharger system really struggles to wake up and that's when an electric booster can fill the boost gap.

One of the biggest enemies of a powerful electrical system is the heat it generates and controllers for e-boosters are no exception. Because the electric motors generate high torque, controllers quickly get hot, limiting the time motors can run without a break. Aeristech has rethought the design of the power electronics behind the e-booster to lessen the amount of heat it generates without reducing the torque. That means it can be used full time for boosting and replace exhaust-driven turbochargers.

The new electrical architecture separates control of the motor's revs from the amount of torque it generates. Normally, both are controlled together, but under the new regime, the amount of heat generated by the controller is dramatically reduced. Not only can the motor be run for longer but it can be run much faster than usual. Typically, e-boosters are designed to run at up to 70,000rpm before the limitations of

the electronic control system kick in. With the Aeristech design, there are no electronic limits and 48V e-boosters have been tested at up to 120,000rpm.

The benefit of switching to pure e-boosting is appealing on several levels. It could also be used on small, 1.2- to 1.5-litre downsized petrol engines, which, like diesels, produce less of the exhaust gas energy at low speeds that a turbocharger needs to work properly. Removing the turbocharger from the exhaust system means the catalytic converter can be moved closer to the engine to clean up tailpipe emissions more effectively, too. It also gets rid of the exhaust back pressure that a turbocharger causes, which ironically can be bad for fuel consumption.

The new control system can be used for air pumps as well, such as those needed in fuel cell stacks, and a booster could be used in conjunction with electrically heated e-catalytic converters to get on top of emissions even before an engine has been started.

BLINK AND YOU'LL MISS IT

Hyundai parts supplier Hyundai Mobis is working on a novel roof-mounted airbag to prevent occupants from being ejected via a sunroof during a rollover. First revealed in 2017, the system is still being refined by the company but basically it deploys along two rails either side of a panoramic sunroof in 80 milliseconds, or about five times faster than the blink of an eye.



Williams Advanced Engineering has donated its spare PPE gear, including masks and gloves, to Oxford's John Radcliffe Hospital and smaller surgeries near its factory.



Car firms step up to help NHS

How the industry's expertise is being applied to producing medical equipment

The National Health Service's urgent need for more ventilators and other medical equipment to help treat patients suffering from Covid-19 sparked an incredible response from UK industry, including a huge number of automotive and motorsport firms.

On 16 March, the government called for manufacturing firms to assist with rapid high-volume production of mechanical ventilators, which are designed to assist critically ill patients with breathing and other functions. Several consortiums were formed in response, and within 15 days the first ventilators resulting from those efforts had been produced and were ready.

So how have firms put automotive and motorsport expertise to use producing medical equipment?

Williams Advanced Engineering (WAE), originally formed to apply technology developed by the Williams Grand Prix team to other industries, has played a major role in the VentilatorChallengeUK

consortium. While Ford and the seven UK-based Formula 1 teams are involved, the consortium is largely comprised of aerospace firms, including Airbus, BAE Systems and GKN Aerospace, and medical equipment companies such as Penlon and Renishaw.

WAE boss Craig Wilson said the firm took the decision to join VentilatorChallengeUK because it had pre-existing relationships with a number of those involved. "It meant we didn't need to get to know each other, so we could quickly start to make a difference," he said.

VentilatorChallengeUK also appealed to WAE because, rather than work on a new ventilator design as some firms and consortiums have done,

the group opted to increase production of a device already made by Smiths Medical.

"We decided it was best to work with an existing design," said Wilson. "Like any motorsport business, we look at the risk for any engineering routes we might take and the best way to add value. The Smiths device is currently in service, so once we scale up production, we can have the units operating quickly with no regulatory tests needed."

The varied companies in the consortium each have a diverse range of specialisms and manufacturing capabilities, and to ensure ventilators could be produced as quickly as possible it was key to harness each firm's skills.

For WAE, that meant taking a lead in reverse-engineering an existing Smiths ventilator to create the information that will allow the larger firms to produce parts. "The mindset throughout the

"We've got a talented team who are used to manufacturing both quickly and appropriately"

consortium recognised that we just needed to do this, so normal arrangements went out the window so we could get on as quickly as possible," said Wilson. "The idea was to scale production using four or five high-volume assembly lines, with the aerospace firms working to accelerate their supply chains. But information for the parts didn't exist in 3D CAD files, so we had to reverse-engineer a unit, take it apart and produce those for every part, along with a bill of materials. It was our first activity and key to getting the project running at speed."

WAE completed that task in just over a week, with around 50 staff working on the project. While most operated remotely, a handful worked - with appropriate measures in place - at WAE's Oxfordshire factory.

"As well as creating the 3D

models, we built two prototype units based on our reverse-engineering designs, which were then validated by Smiths to ensure they were the same standard," added Wilson.

WAE has also been involved in using validation techniques developed for motorsport projects to set up a testing process for the ventilators that will be produced on the various production lines.

"Because of our motorsport heritage, we're very good at getting answers to problems and then just getting on and solving it," said Wilson. "It's in our DNA. Bigger companies don't have the same agility and 'just do it' mentality baked into them. But they have scale: aerospace firms have supply chains on a completely different volume to the automotive industry."

Within three weeks



WAE is making a Smiths Medical ventilator design

PETROL PLUMMETS AS DEMAND DROPS

Petrol could drop below £1 per litre, according to RAC Fuel Watch. Crude oil is currently £24 a barrel - half the price it was in March - with lack of demand a big factor. The RAC says a supermarket price war will hit rural independent fuel retailers.



ELECTRIC SKODA CITIGO SELLS OUT

Skoda has removed the new Citigo-e iV from sale after all 400 UK examples sold out in less than two months. The brand's first EV arrived in late January. A spokesperson said it will return to market when Skoda's factory shutdown ends.





HOW COVID-19 IS AFFECTING THE INDUSTRY

New car sales slump
UK new car registrations fell by 44.4% year on year in March as a result of the nationwide lockdown that closed dealerships and kept customers at home. A total of 254,684 cars were sold.

JLR making visors
Jaguar Land Rover has begun production of NHS-approved plastic visors at its Gaydon plant, with the aim of eventually making around 5000 examples each week. The firm is making the CAD files for the design available so that other firms can also put it into production.

Aid for key workers
Several car firms are offering free roadside assistance to NHS or key workers who drive their vehicles, regardless of the car's age. Firms with such schemes include the PSA Group (Citroën, DS, Peugeot and Vauxhall), Toyota and Lexus.

Clean Air Zones delayed
The government is postponing the planned roll-out of Clean Air Zones in cities such as Bristol, Leeds and Birmingham until next year to allow freight businesses to focus on delivering vital goods and services during the pandemic.

Ford offers six-month payment holiday
Ford has introduced a six-month payment holiday for all customers who purchase a new car or van on finance in April or May. Under the scheme, Ford will cover the first three monthly instalments and delay the following three instalments.

everyone is both unbelievable and incredibly inspiring. We're just helping to supply equipment to ensure they can do the really vital work."
JAMES ATTWOOD

of the call to action, the VentilatorChallengeUK consortium is now producing around 1500 ventilators per week, with a government order to supply at least 10,000 units. While it seems an incredibly quick turnaround, Wilson said it's something that WAE is used to from motorsport and automotive projects.

"We've got a talented team of engineers who are used to manufacturing both quickly and appropriately," said Wilson. "Working on projects at such speed is something the company does regularly. We faced similar time constraints when we were preparing the Jaguar C-X75 fleet for the James Bond Spectre film. "Obviously, this project is of national importance, and the team were hugely motivated for it. We supported it at the highest levels of the company, and it's fantastic that we had the ability to contribute to a project that can make a real difference."

As Wilson noted, the role of the consortium is ultimately a supporting one. "It's all to help the NHS and its staff," he said. "What they're doing for

Precept to inspire Polestar SUV

POLESTAR'S PIVOTAL THIRD model, which is expected next year, will take heavy styling inspiration from the recently revealed Precept concept.

Polestar head of design Max Missoni said a production version of the Precept saloon hasn't been confirmed, but it will definitely influence future cars. "The design language of that car is something you can and should expect in our future cars, starting with the Polestar 3," he said.

The 3 SUV, which will follow the 1 plug-in hybrid coupé and 2 electric fastback, can therefore be expected to continue Polestar's design

departure from parent company Volvo, with an aerodynamically focused profile, a pointed front end and a wraparound tail-light bar among its features.

Missoni further hinted at the 3's billing as a sleek, minimalist Tesla Model X rival. "Our next car will be a performance SUV - the Polestar 3 - and that will carry some of the features and design cues you've seen in the Precept," he said.

"We're really keen on keeping a minimalistic surface to things, keeping things extremely pure and clear," he added, suggesting

the 3 will feature a simple interior like that of the 2, which eschews buttons and switches in favour of a large central touchscreen.

Despite likely to be riding higher and weighing more than Polestar's current production cars, the 3 will stay true to the brand's premium performance values and deliver pleasing dynamics.

"We want the cars to be performance cars, not only from 0-60 but [also] great driver's cars with good driving dynamics," Missoni said. "All of our cars - especially with the performance pack - will fulfil some of those desires."



Precept could reach production itself as a Tesla Model S rival

GATERHAM EVOKES HALCYON DAYS WITH NEW SUPER SEVEN

Caterham has launched a new version of the Seven aimed at combining 1970s design inspiration with modern performance. The Super Seven 1600 revives the spirit of the original Super Seven and includes classic flared front wings, 14in wheels and a wood-rimmed steering wheel.

The Super Seven's 1.6-litre Ford Sigma engine has 135bhp, making for a 0-60mph acceleration time of 5.0sec.

Caterham says throttle body injection by DCOE gives the car a distinctive 1970s soundtrack.

The Super Seven 1600 is priced from £33,495.



Super Seven 1600 features period design touches

AUTOCAR EXTENDS BTCC BACKING

Autocar will remain a media partner of the British Touring Car Championship for the next three seasons, extending a deal that began in 2014. We will continue to provide news and features coverage of Britain's biggest motorsport series.



SPEEDERS ESCAPE PROSECUTION

Speeding drivers are getting written warnings due to increased police workloads amid the pandemic, The Times reports. Letters sent to offenders say it's "not in the public interest" to prosecute at this time. Speed awareness courses are also on hold.



MOTORSPORT IMAGES

FIRST DRIVES

NEW CARS TESTED AND RATED



TESTED 17.3.20, STUTTGART, GERMANY ON SALE JULY PRICE £155,970

PORSCHE 911 TURBO S

Range-topping version of iconic sports car gets a host of key technical upgrades, including a new engine that makes it the quickest 911 yet



Among Porsche enthusiasts – well, any car enthusiasts, really – the combination of the number 911 and the word Turbo has long enjoyed cult status.

Back in 1974, Porsche redefined road car performance with the original 911 Turbo, fitting a turbocharged engine and an oversized rear wing to its signature model to create the legend that exists today. Ever since, the company has striven to refine the fundamental formula, even if there has been the odd change in philosophy along the way.

Almost half a century later, we now have the seventh-generation 911 Turbo: the 992. It replaces the facelifted version of the 991-series 911 Turbo that was launched in 2016 and comes at a time when Porsche, with a record number of new petrol-engined and electric models in the pipeline, appears to be very much at the top of its game.

In its headlining S guise, the new Turbo looks familiarly purposeful and muscular in the metal. Its lines clearly draw from the model it replaces, albeit with new detailing, most notably to the round LED headlights and new full-width tail-light assembly.

And yes, it's wider than ever

before – 48mm wider than the base 911 Carrera, to be precise. Although the 992 is based on the same platform as its predecessor, with a 2450mm wheelbase, its aluminium body has been widened to further accentuate the Coke-bottle form built up over more recent generations.

The increase is necessitated by the adoption of a 42mm-wider front track and 10mm-wider rear track, together with, for the first time, the combination of standard 20x9.0in front and 21x11.5in rear wheels.

All up, the car is 28mm longer and 20mm wider than the old Turbo S, at a respective 4535mm and 1900mm. Despite a number of weight-saving measures, including new optional composite glass that's claimed to weigh some 4kg less than the glass used before, it has also gained 40kg, giving it a kerb weight of 1640kg. That's due mainly to the introduction of a more advanced dual-clutch automatic gearbox and other key developments that include new brakes and the larger wheels needed to accommodate them.

The aerodynamic functions have been reworked too. Together with the active front spoiler ducts →



“
The remarkable thing is just how amenable the car is
”

Driving position is excellent and all around you is of luxurious quality

← brought over from its predecessor in a revised form, the Turbo S gets a reworked rear spoiler offering Speed and Performance settings, with the latter contributing to a 15% improvement in downforce. There's also a new air brake function to increase drag at high braking speeds.

As before, buyers can choose a coupé or cabriolet body, the former of which we will concentrate on here.

The 992 abandons the 3.8-litre flat-six engine that has been a mainstay of the Turbo since the facelifted version of the 996 was launched in 2009 for an all-new powerplant that, despite giving away 14% in overall capacity, offers greater power and torque than before.

There are no official engine output figures for the standard Turbo just yet. But in the Turbo S, power has increased by 68bhp to 641bhp at 6750rpm, endowing the coupé with a 20bhp boost at 233bhp per litre and a power-to-weight ratio of 391bhp per tonne. Torque also climbs by 37lb ft to 590lb ft between 2500 and 4000rpm. For perspective, that's 50bhp less but 37lb ft more than the most extreme roadgoing 911 to date, the GT2 RS.

These added reserves, not least the increase in torque, have brought about an upgraded eight-speed gearbox as well as a new front axle transmission for the multi-plate-clutch four-wheel drive system.

The cabin represents a big

improvement over the old model, with a new steering wheel hosting shift paddles and a driving mode controller, a high-definition digital instrument display, a 10.9in infotainment touchscreen and a neatly organised centre console. It's all of a suitably high quality.

Yet despite its increase in exterior dimensions, the 911 is still a strict 2+2, with 128 litres of luggage capacity in its nose. When the rear backrests are folded down, a further 264 litres of stowage becomes available behind the front seats.

There's a lovely familiar meshing of mechanical clatter as the ignition fires. This engine may be new, but it continues to make all the right noises. At idle, the pulsating action of the

horizontally opposed six cylinders hung out back drowns out the sound of the exhaust. However, that changes the moment you draw the stubby gear selector backwards and set off down the road.

The new Turbo S is typically well mannered in Comfort mode around town. It's not exactly quiet, but neither is it ever particularly raucous. There's greater intent to the gravel-toned exhaust note than before, thanks to the availability of an optional sports exhaust – as fitted to our test car – for the first time. However, it's still relatively subdued.

Until you call up Sport mode and plant it, that is, at which point it unleashes a gloriously deep blare that's less guttural but every bit as

captivating as those of Porsche's naturally aspirated powerplants.

The remarkable thing – and this has been a key strength of the top-of-the-line 911 for years now – is just how amenable the car is. Threading through traffic and heading beyond the suburbs onto smooth-surfaced country roads, it really is as easy to drive as your average hot hatchback.

Only it's in a completely different dimension as far as performance is concerned. The acceleration in lower gears is mind-numbing in its intensity. Porsche claims 0-60mph in 2.6sec, a 0.2sec improvement over the old Turbo S, making this the fastest-accelerating series-production 911 yet. Yes, that means it's quicker here than the GT1, GT2 RS and GT3 RS.

The savage low-to-mid-range thrust and ability of the four-wheel drive system to place it to the road with outstanding efficiency make for explosive forward momentum, as exemplified in the 0-124mph time, which has been improved by a full second to just 8.9sec.

There's so much torque available that you can call up higher gears and surf the resulting potency well into significant three-figure speeds in one wonderful unbroken line of surging acceleration, aided all the while by the stunning straight-line stability brought on by 170kg of downforce at the claimed 205mph top speed.

There's no noticeable turbo lag →



Turbo has been widened once again; active wing adds yet more downforce



TESTER'S NOTE

The new 911 Turbo is quite a heavy car, tipping the scales at 135kg more than the base 911 Carrera. However, it doesn't feel it. There's an engaging fluidity to its actions that marks it out as not just a devastatingly effective grand tourer but also, with just a turn of the driving mode controller, a true sports car. **GK**



Turbo S is furiously quick at full chat and sounds suitably menacing

← anywhere, just one exceptional stream of urge from not much more than 1000rpm all the way to the 7200rpm ignition cut-out on a loaded throttle.

The smoothness of the delivery and rapid action of the kickdown from the gearbox mask the improved response of the new engine, but it is there. This latest version of Porsche's traditional six-cylinder unit isn't rabid in the character of a flat-plane-crank engine, but there's still added resolve to the way it goes about its business. That's especially

true at the upper end of its rev range, where it feels stronger and more determined than its predecessor.

There's more to the dynamic appeal of the Turbo S than just its straight-line speed, though, and that all starts with the steering. There's a lovely slickness and immediacy to the speed-sensitive electromechanical four-wheel system.

The weighting remains consistent over a wide speed range, creating the sort of engagement that no recent Turbo S has managed to offer. In a bid to improve agility, Porsche has

revised the steering action on the rear wheels, increasing the ratio by 6% for even sharper and more decisive turn-in traits than before.

For the first time, Turbo S buyers can specify optional sports suspension with a 10mm-lower ride height and retuned active roll compensation system among other detailed changes over the standard underpinnings. This is allied as standard to the Porsche Active Suspension Management system, which brings adaptive damping into the mix.

Also on the optional equipment list is a lift function that provides an additional 40mm increase in ground clearance on the front axle.

The sports suspension breathes nicely over longer-wave undulations and remains superbly controlled over higher-frequency bumps, without the characteristic nose bob that affected previous generations, keeping the Turbo S well planted on all but the most badly pitted surfaces. This is thanks in part to the adoption of new helper springs that provide a preloading effect to the main springs for more controlled rebound.

If there's a weakness, it's the incessant road roar on anything but super-smooth surfaces, especially from the rear end. Still, the tuning really is sweetly struck, bestowing the new model with adequately absorbent long-distance properties in Comfort mode and a firm but controlled ride in both Sport and Sport Plus modes.

All this makes the new Turbo S, a car that makes well over twice the power of the original, eminently approachable. Yes, it's absurdly fast, but the calmness of its ride and its otherwise superb resistance to pitch and dive under acceleration and braking is all the elixir you need to take full advantage of its exceptional grip, which now comes via a combination of standard 255/35-profile tyres at the front



Latest 911's interior deftly mixes retro cues with the latest technology

“
It feels deliciously
well planted from entry
to apex and beyond
”



Torque-vectoring four-wheel drive system makes for splendid handling

and 315/30-profile tyres at the rear.

The combination of this new rubber and the latest incarnation of Porsche's four-wheel drive system, which uses a lighter and more rigid driveshaft and a single universal joint to the front wheels, delivers huge traction and purchase.

Tip the car into a fast corner and it displays exceptional body control, while remaining unflinching in its determination to hold your chosen line. The changes to the four-wheel drive system now allow up to 369lb ft of torque to be apportioned to the

front wheels. The torque-vectoring effect at the rear is also improved.

Given the 911's distinctive rear-biased weight distribution, it feels deliciously well planted and neutral from entry to apex and beyond.

There's a trace of steady understeer when you're really on it, as you would hope for and expect from something capable of generating such high cornering speeds. However, unshackling the stability control system brings a degree of adjustability that enthusiast drivers may seek in tighter bends. The limits

of adhesion are so high, though, that you would need to be on a race circuit to really explore the car's true ability.

This also applies to the brakes, which now feature carbon-ceramic discs of 420x40mm at the front and 390x32mm at the rear in combination with huge 10-pot front calipers and four-pot rear calipers. They're incredibly effective, providing reassuring bite in the initial degrees of travel and strong but progressive qualities as you add further pressure to the pedal thereafter.

UPGRADES SMALL BUT SIGNIFICANT

The new twin-turbocharged horizontally opposed six-cylinder engine of the 911 Turbo is based on the 2981cc unit used by the latest 911 Carrera. It has an 11mm increase in bore, at 102mm, giving it a swept volume of 3745cc - some 55cc less than the engine it has replaced. Developments include larger, variable-geometry turbochargers operating at up to 1.4bar of pressure. The diameter of the turbine wheels is increased by 5mm to 55mm, while the 61mm compressor wheel is 3mm larger than before. Also new are electronically controlled wastegate flaps; a charge air cooling system with new routing from the side air intakes and rear spoiler; revised piezo injectors; and a petrol particulate filter. With its increases in power and torque, the new engine is mated to a new eight-speed dual-clutch automatic gearbox that has a shorter first gear, a longer top gear and a longer final drive than the old seven-speeder. In keeping with other new 911 variants, there's also now a Wet driving mode for the range-topper.



The strength of the new Turbo S lies in the breadth of its repertoire: it eases and thrills in equal measure. It doesn't quite deliver the same whip-crack reactions and at-the-wheel sensitivity of some competition-bred 911s, but what it lacks in sheer tactility is more than made up for in its speed and ability to swallow big distances at legal limits in relative comfort without ever needing to work hard at all. It's arguably the world's most complete and versatile all-season supercar.

GREG KABLE

PORSCHE 911 TURBO S

Following the evolutionary path, the latest 911 Turbo delivers new levels of performance and driving thrills



Price	£155,970
Engine	6 cyls, 3745cc, twin-turbocharged, petrol
Power	641bhp at 6750rpm
Torque	590lb ft at 2500-4000rpm
Gearbox	8-spd dual-clutch automatic
Kerb weight	1640kg
0-60mph	2.6sec
Top speed	205mph
Economy	25.4mpg
CO ₂ , tax band	254g/km, 37%
RIVALS	Aston Martin Vantage, BMW M8 Coupé, Mercedes-AMG GT S Coupé



Front seats are very comfortable but rears are still best left for luggage



TESTED 25.3.20, INGOLSTADT, GERMANY ON SALE JUNE PRICE £79,900

AUDI E-TRON SPORTBACK

Coupé version of Audi's first dedicated EV promises to be more engaging to drive. A true alternative to the excellent I-Pace, then?





This is the car with which Audi is aiming to challenge the Jaguar I-Pace for zero-emissions SUV driving honours.

The E-tron Sportback 55 quattro, as its name suggests, is a more sporting version of the E-tron 55 quattro that has been on sale here since mid-2019. Outwardly, it's distinguished from its sibling by a more heavily curved, coupé-like roofline and liftback-style tailgate, among other subtle changes, including more aggressively styled bumpers and headlights using Audi's new digital matrix LED technology.

Together, these alterations provide the E-tron Sportback with a shapely profile similar in style and detailing to the Elaine concept that Audi unveiled three years ago.

Sharing certain exterior design elements with conventionally powered Audi models, it's perhaps not as distinctive as the I-Pace. But with a drag coefficient of just 0.25Cd, it's among the most aerodynamically efficient series-production SUVs yet, beating the Jaguar in this crucial area by a considerable 0.04Cd margin. This is thanks in part to the availability of 'virtual exterior mirrors', which use a camera to project a live video feed on the forward part of the doors inside.

The changes to the cabin over the regular E-tron are slight, but that's no bad thing. In terms of attractiveness, perceived quality and tactility, the dashboard, controls and trim materials are all premium in nature.

The optional front sports seats are firm and supportive, setting up a pleasantly roomy and airy driving environment. However, accommodation in the rear is compromised to the tune of 20mm by that plunging roofline. The adoption of a more heavily angled tailgate also reduces boot capacity by 45 litres over the E-tron, at 615 litres. Even so, it's still quite versatile, with 58 litres more than the I-Pace.

Like the E-tron (alongside which it's produced at Audi's factory in Brussels, Belgium), the E-tron Sportback is based on a modified version of the MLB Evo platform, housing between its axles a sizeable

95kWh lithium ion battery made up of cells supplied by LG Chem.

At 4901mm long, 1935mm wide and 1616mm tall, the E-tron Sportback is 85mm shorter, 60mm narrower and a considerable 89mm lower than Audi's conventionally powered flagship SUV, the Q8.

The drivetrain is borrowed wholly from the E-tron. It uses two differently specified asynchronous electric motors, one sitting up front that produces peaks of 181bhp and 182lb ft of torque and a second at the rear making 221bhp and 232lb ft.

Together, they provide a maximum system output of 402bhp and 490lb ft for limited periods of up to eight seconds in Boost mode, which is activated by slotting the gear selector into S. In D, the combined output of the motors is reduced to a milder 355bhp and 414lb ft to help increase efficiency and consequently extend the range between charges.

The I-Pace's two motors, by way of comparison, deliver a maximum combined 394bhp and 512lb ft.

Power is sent to all four wheels via a single-speed gearbox attached to each motor and networked via a central power electrics system. In a key departure from its more practical sister, however, the E-tron Sportback features a decoupling mechanism between its front and rear axles.

This enables it to send its drive exclusively to the rear wheels in everyday driving in D, giving it an additional seven miles of range over the E-tron, at 278 miles. It's only when you call up greater reserves via the kickdown function in S that the other motor is called upon and the front wheels begin to do the driving.

Acceleration off the line is strong but far from explosive in D, owing in part to the E-tron Sportback's hefty 2480kg kerb weight and the considerable amount of energy required to set it in motion. Once you've built up initial momentum, though, rolling acceleration is quite sharp. Keep the throttle nailed thereafter and the car will dispatch you beyond the British motorway speed limit with a good deal of force.

Selecting S instantly heightens →



Driving environment is impressive but steering is numb



TESTER'S NOTE

The use of an MLB-derived platform means the E-tron Sportback suffers the same packaging problems as regular Audi SUVs. Without the long bonnet and bulky transmission tunnel, it would be even roomier and more versatile. **GK**

“
Audi has managed to take acoustic civility to a whole new level
”



Standard-setting refinement and a comfy ride make for relaxing journeys

← the performance further, providing more responsive tip-in, noticeably stronger roll-on qualities and greater overall performance intensity. So configured, the car has a claimed 0-62mph time of 5.7sec, but from recent experience with the E-tron, we wouldn't be surprised if that time is a little on the conservative side. The E-tron Sportback certainly feels quicker once all that torque is flowing freely to each wheel, and the inherent urgency doesn't subside until you're well on the way to the electronically

limited top speed of 124mph.

For perspective, Jaguar claims figures of 4.8sec and 124mph.

Satisfaction doesn't only come via the accelerative forces at play, though. An advanced kinetic energy recuperation system with three selectable degrees of intensity (in addition to an automatic setting that draws on the sat-nav for topographic information) also demands a degree of skill from the driver, in seeing how much energy can be harvested under braking and during periods

of off-throttle coasting.

In its automatic setting, the system is amazingly efficient, although it does take some trial and error before you fully understand what setting best suits any particular situation.

Another real strong point of the E-tron Sportback is its outstanding refinement. We've become used to the inherent quietness of electric cars, but Audi has managed to take acoustic civility to a whole new level. Rolling refinement, suppression of road noise and resistance to wind

buffeting are particularly good, even at motorway speeds. The near-silent operation of the motors and power electronics system is excellently isolated from the cabin too, making the E-tron Sportback very relaxing to drive over long distances, especially in its more comfort-focused mode.

Given the E-tron Sportback's outstanding ability to place those not-inconsiderable reserves to the road, it's a pity that its steering doesn't offer more feel; the speed-sensitive electromechanical rack delivers a reassuring sense of sharpness and weighting but is lacking in feedback.

Don't let that shortcoming put you off, though, because the E-tron Sportback still offers enough for the driver to be described as engaging. It's capable of stringing together a series of medium-to-high-speed corners with excellent resistance to roll and some proper rear-biased handling properties.

With the majority of its weight concentrated low within its platform and a comparatively low ride height by SUV standards, it has a very low centre of gravity and can offer the sort of assured handling traits that promise to win it wide appeal.

Despite heady levels of weight transfer under braking and in tight corners, body movement is excellently suppressed thanks to



Sloping roofline at rear was taken from the A7 Sportback five-door coupé

AUDI IMPROVES ITS MANAGEMENT SKILLS



The E-tron Sportback 55 quattro's 95kWh battery pack can be charged at a rate of up to 150kW and from both sides of the car. Audi claims that charging from 20-80% of its capacity can take half an hour and that from 20-100% can take 50 minutes. Drawing on experience gained from the regular E-tron 55 quattro, Audi has reworked the cooling system for the battery. Instead of using two water pumps, the E-tron Sportback uses a larger single unit, saving weight, cost and energy. This key difference is claimed to contribute up to 1.2 miles of the seven-mile increase in range that the E-tron Sportback has achieved over the E-tron.



Digital dial display sits alongside touchscreens spanning 10.1in and 8.8in

a combination of firm damping and fast-acting qualities of the standard air suspension. Lean isn't entirely absent, but the degree of it is relatively low and sufficiently progressive so as not to upset the otherwise respectable balance.

The ability of the quattro four-wheel drive system and its torque-vectoring system to individually apportion power to each rear wheel helps to provide a decent amount of purchase on smooth surfaces, too.

The optional 255/50-profile tyres

worn by our test car deliver plenty of mid-corner grip, allowing you to carry a good deal of speed up to the apex without any premature understeer or intervention from the electronic stability control system. Thereafter, you can be very prodigious with the throttle without causing any deterioration of poise.

In the UK, the E-tron Sportback comes as standard on big 21in alloys, but buyers will also be able to specify 22in wheels as an option. On the 20in rims available in Germany,

the ride is nicely struck, with firm underlying qualities providing well-controlled vertical movement.

A further point of note is the outstanding feel of the E-tron Sportback's brake pedal, which is among the best we've come across in an electric car of any guise. Despite there being four different intensities of energy recuperation available, the feel remains strong and positive at all times.

Changes over the regular E-tron to the brake pads, including the

adoption of softer springs, have reduced friction, Audi says, eking out another 1.9 miles of range.

The £79,900 E-tron Sportback is more driver-oriented than the £71,520 E-tron, if not quite to the degree we were led to believe by Audi when revealing it at the Los Angeles motor show last year. The difference between the two is quite subtle on pure performance alone.

However, with a more sporting shape, greater athleticism on more challenging roads, further improved refinement and a superb interior that continues to offer a good deal of everyday versatility, despite the coupé redesign, the E-tron Sportback sets a high standard among the electric SUV ranks.

It's certainly one the I-Pace won't have an easy time surpassing when we get to put the two side by side after the lockdown.

GREG KABLE



E-tron's rear light bar appears again on the Sportback



AUDI E-TRON SPORTBACK 55 QUATTRO

Quick, quiet and classy electric SUV builds on the solid foundations of its upright sibling with sharper handling



Price	£79,900
Engine	Two electric motors
Power	402bhp (in Boost mode)
Torque	490lb ft (in Boost mode)
Gearbox	1-spd, direct drive
Kerb weight	2480kg
0-62mph	5.7sec (in Boost mode)
Top speed	124mph (governed)
Battery	95kWh
Range	278 miles (WLTP)
CO₂, tax band	0g/km, 0%

RIVALS Jaguar I-Pace, Tesla Model X



TESTED 12.3.20, GRANADA, SPAIN ON SALE MAY PRICE £31,650 (FROM £24,900)

AUDI A3 SPORTBACK

New family hatch takes the fight to the A-Class and 1 Series with more tech, classier looks and - shock! - a more rewarding drive



Since its introduction in 1999, the Audi A3 has been the conservative and consistent, if somewhat predictable, option in the premium family hatchback class. Now into its fourth generation, it's no longer available with a three-door body, but to compensate Audi has created a more appealing design for the five-door Sportback version.

Just like its new-generation Seat Leon, Skoda Octavia and Volkswagen Golf relations, the new A3 uses an evolution of the Volkswagen Group's ubiquitous MQB platform, with

enhancements to accommodate a wider spread of powertrain options that will include mild-hybrid and plug-in hybrid variants.

Three main trim levels will make up the A3 range: Sport, Technik and S line, with each receiving subtle exterior styling differences. In the case of Technik and S line, the headlights feature a small panel of 15 LEDs that provides different light signatures for each version to give greater visual differentiation. Audi distinguishes the S line exterior further with larger honeycomb structures for the side vents →

← and the three Quattro-inspired (blacked-off) slots in the front of the bonnet. Higher-spec Edition 1 and Vorsprung versions will arrive later.

Anyone stepping out of the relatively minimalist cabin of the previous A3 and into this new one will be in for a shock, albeit mostly a pleasant one. There is a wider variety of materials and a dashboard that is, to a degree, split in two, with a more driver-focused design.

Every new A3 comes with a 10.25in digital instrument display as standard and Audi offers a larger, 12.3in version (as already featured in several of its other models) as an optional upgrade. There's also a 10.1in touchscreen that runs Audi's latest MIB3 infotainment system. Smartphone mirroring for Android and Apple devices is available, although not wirelessly at launch. Usefully, there are both USB-A and USB-C ports in the centre console and an angled wireless device charging pad.

As in other smaller models in the Audi range, there isn't a secondary touchscreen for the climate control settings. Instead, there's a small cluster in the lower section of the dashboard with easy-to-reach physical buttons that make frequent adjustments possible without glancing away from the road. This is the preferable set-up in our opinion.

The A3's seats are also new and, in a bid to improve its environmental credentials, Audi now uses materials



There's a good mix of comfort and control on standard passive suspension

for the inlays that are manufactured from recycled PET bottles. According to the company, each A3 uses 45 discarded 1.5-litre plastic bottles in every set of seats that feature the new material.

Aside from that, there's 6mm more elbow room in the front and 3mm more in the rear, thanks to an increase in the car's width. A 7mm increase in front head room and 2mm more shoulder room are also welcome, if small, improvements. The boot capacity of the A3 remains the same as in the previous generation, at 380 litres, and this increases to 1200 litres when the rear seats are folded forward. From

Sport specification up, these are split 40:20:40, rather than 40:60.

Audi hasn't enjoyed a stellar reputation for giving its cars involving steering feel but, while the A3 isn't pitched as the last bastion of engaging dynamics, most buyers won't have cause for complaint. All of the models we drove came equipped with Audi's optional Progressive Steering, which uses a variable ratio rack. This makes the steering more direct the more you turn the wheel, which is great for parking, because you can get from lock to lock speedily, but it also makes the A3 feel incredibly biddable when attacking a sequence of especially tight corners.

The variable ratio allows this without making the steering overly sensitive at or near the straight-ahead position. It's a worthwhile upgrade no matter where you spend most of your time driving. Incidentally, the standard power steering system is electromechanical, with speed-sensitive assistance.

Drivers can further adjust the feel of the steering by toggling through the different modes in the Drive Select function (available from Sport trim). We found that it was only the sportier Dynamic mode that made any real difference, predictably weighting up the steering to require more input force from the driver. And actually, as you wind on lock in this setting, there's an unpleasant amount of resistance, so we feel the steering is best left in the default mode.

Better in operation is the adaptive suspension, again an option, which lowers the ride height by 10mm. It uses a new system with specially designed valves in the dampers to alter the rate of flow, thus allowing for a greater difference between the Comfort and Sport settings than with previous systems. Driven back to back with an A3 on passive suspension, the greater distinction between the settings is immediately obvious. However, the standard set-up still offers a good compromise between comfort and body control, so the upgrade isn't strictly necessary. An 11mm-wider track raises



“ Its core strengths include a far better interior and a more polished drive than before ”

Cabin gains a wider range of materials and has a 10.25in digital driver display and a 10.1in touchscreen as standard



A3 hatchbacks are five-door only this time but Audi has created a more overtly sporty-looking design



TESTER'S NOTE
Audi's new adaptive suspension set-up includes three-axis accelerometers to detect movement and surface conditions, acting independently to adjust the dampers on all four corners in near-real time. **DH**

GET A HEADS-UP ON A HEAD-UP DISPLAY

An interesting feature making its debut on the A3 - Audi claims it's a world first - is head-up-ready preparation. The design of the instrument binnacle makes it much easier to add in the colour head-up display at a later date, because the preparation kit can be pre-installed at the factory.

According to Audi's engineers, it will be far easier for dealers to upgrade this kit by removing the steering wheel and digital screen before slotting in the head-up display hardware. The large colour display can then project directly onto the windscreen.

This may prompt some retailers to order cars for stock with the preparation pre-installed to either sell as an upgrade to customers or to add to used stock returning from PCP deals later to improve a car's appeal in the used market.



cornering speeds and stability across the board, in comparison with the outgoing A3, but the sophistication of the suspension underneath varies across the line-up. If your A3 has less than 148bhp, it gets a torsion-beam rear axle. The more powerful variants benefit from superior multi-link suspension with a separate spring and damper design. Finally, the S line comes with a stiffer passive set-up as standard, reducing the ride height and centre of gravity by 15mm.

All of the A3's engines have been re-engineered and, in the case of the 35 TDI (2.0-litre four-cylinder diesel), this has resulted in quieter operation.

It certainly feels smoother than previous iterations of this unit did, too. When matched with the S tronic seven-speed automatic gearbox, it makes for an ideal long-distance driver. All diesel A3 engines also gain a twin-dosing AdBlue system to help reduce NOx emissions, especially at higher speeds.

A few months after the initial roll-out in the UK, the A3 line-up will be expanded by the introduction of a 114bhp diesel version (still a 2.0-litre but badged 30 TDI) with a more tempting benefit-in-kind tax rate - as low as 21%, depending on spec - that will undoubtedly appeal to company car drivers.

While maintaining a similar power output to the older 1.6-litre TDI engine, the only noticeable area that this 2.0-litre unit concedes to its more powerful relation is outright acceleration. Once up to speed, it clips along nicely, and a drive with the six-speed manual confirms that this less potent version still makes for a sensible buy.

Smoother still is the 48V mild-hybrid petrol 35 TFSI. Its BAS (belt alternator/starter) ensures near-seamless engine restarts at traffic lights and can provide for engine-off coasting at up to 100mph to save fuel. The only blot in its copybook is a wooden-feeling brake pedal,

presumably due to how it links with the mild-hybrid system to provide energy recuperation when slowing.

The turbocharged 1.5-litre petrol engine will be available without the BAS, featuring the cylinder-on-demand technology that enables it to run on two cylinders during lighter engine loads.

Regardless of which engine you go for, the A3's core strengths are its exterior design, a significantly improved interior and a more polished driving experience than before. It bodes well for the model line as it expands to sportier S3 models and beyond.

DAVE HUMPHREYS



Boot is 380 litres, as before, but swells to 1200 litres with the rear seats down



AUDI A3 SPORTBACK 35 TDI S LINE S TRONIC

Bolder design, more choice and improved driving dynamics make the A3 stand out more than ever



Price	£31,650 (from £24,900)
Engine	4 cyls, 1968cc, turbo, diesel
Power	148bhp at 3000-4200rpm
Torque	265lb ft at 1600-2750rpm
Gearbox	7-spd automatic
Kerb weight	1410kg
0-62mph	8.4sec
Top speed	139mph
Economy	72.4-76.3mpg
CO₂, tax band	98-103g/km, 22-23%
RIVALS	BMW 1 Series, Mercedes-Benz A-Class, VW Golf

TESTED 18.3.20, STUTTGART, GERMANY ON SALE SUMMER PRICE £37,700 (EST)

MERCEDES-BENZ GLA 250 4MATIC

Second-generation Audi Q2 and BMW X2 rival rolls out of Stuttgart with a greater emphasis on its crossover billing





The original Mercedes-Benz GLA was an undoubted success from its launch in 2014, with sales that touched the one million mark worldwide. But with all the marketing nonsense that surrounded it stripped away, the high-riding hatchback was in essence not much more than a rebodied version of the third-generation A-Class, and the claim to it being a genuine crossover was somewhat empty in terms of pure function.

This new one is different – and all the better for it. Developed as part of an eight-strong Mercedes compact car line-up, it has been given the necessary design and engineering scope to evolve into a much more rounded and talented rival to the Audi Q2 and BMW X2.

While the mechanical similarities to its lower-riding sibling remain, a whole host of unique touches help not only to provide the second-generation GLA with a more stand-alone character but also to instil the car with the inherent qualities to make it more appealing on many fronts.

Before we get into the finer points of the way the GLA drives, though, we should consider its altered form. Styling is always subjective, so we'll sidestep judgement on the new GLA's bolder appearance. What you should know, however, is that its dimensions have changed: length has been reduced by 14mm to 4410mm, while width extends by 30mm to 1834mm and height is up by a considerable 104mm at 1611mm without the optional roof rails.

By comparison, the Q2 measures 4191mm long, 1794mm wide and 1508mm high, while the BMW X2 stretches to a respective 4360mm, 1824mm and 1526mm.

Don't think the reduction in length has greatly reduced its versatility, though. With a 30mm-longer

wheelbase at 2729mm, its interior has actually grown in size, notably in the rear, where it's now considerably roomier than before.

At its launch, the new GLA will be offered with two different four-cylinder petrol engines and a single four-cylinder diesel engine across seven models, although not all are planned for sale in the UK.

The entry point is the front-wheel-drive GLA 200, which uses a turbocharged 1.3-litre petrol unit sourced from Renault and delivering 161bhp and 184lb ft. It's joined by the initial range-topping GLA 250, in front- and four-wheel-drive guises with a turbocharged 2.0-litre petrol engine making 222bhp and 258lb ft.

The two diesel models, both with the choice of front- or four-wheel drive, use the same turbocharged 2.0-litre four-cylinder powerplant but in differing states of tune. It has 148bhp and 234lb ft in the GLA 200d, while it produces 187bhp and 295lb ft in the GLA 220d.

The GLA 200 is fitted with a standard seven-speed dual-clutch automatic gearbox supplied by Getrag, while all other new GLA models receive an eight-speed dual-clutch gearbox built by Mercedes.

It's the top-of-the-line GLA 250 4Matic we're in here, and the similarities to other recent new Mercedes models can't be denied. Inside, the dashboard, controls and free-standing digital display will be familiar to anyone who has set foot in the latest A-Class hatchback, A-Class Saloon, B-Class, CLA, CLA Shooting Brake or GLB.

Our highly equipped test car featured optional 10.2in twin displays along with a multicolour head-up display unit in place of the pair of standard 7.0in screens, giving it a rather upmarket air that's further accentuated by Mercedes' →



The new GLA is not as long as before but is actually roomier inside

← latest multi-function steering wheel and lots of brushed-aluminium-look trim.

So configured, it's all fittingly premium in look and feel, and with the latest in conversational voice recognition and touchscreen functions within easy reach of the steering wheel, it's quite intuitive, too. The response from the infotainment system and MBUX operating system is particularly impressive, making it easy to set commands on the go.

Befitting the GLA's crossover positioning, its front seats are mounted 140mm higher than those in the A-Class hatchback. In combination with its increased ride height, this provides the GLA with a more commanding driving position. The added height within the body also brings a 22mm increase in front head room compared with the first-generation model.

It's an agreeably airy and relatively spacious driving environment by class standards.

The rear gets a fixed seat as standard but, as with the latest B-Class and the new GLB, there's an optional bench with 140mm of fore and aft adjustment and, crucially, 116mm more rear leg room than before. Longer door apertures with less intrusion from the rear wheel arches also ease entry to the second row, although rear head room has been reduced by 6mm, due to the new GLA's more heavily sloping roofline.

Despite the decrease in overall length, Mercedes has managed to squeeze an extra 14 litres of load volume into the boot, which, with a capacity of 435 litres, now offers 30 litres more than the Q2 but still 35 litres less than the X2.

Out on the road, the GLA 250's engine provides solid performance. It never feels quite as refined as the 2.0 TSI unit used by the Q2 nor as smooth in nature as the engine that powers the X2 xDrive20i. But with little obvious lag and a good deal of low-end torque, it endows the junior Mercedes crossover with purposeful off-the-line and mid-range acceleration, as reflected in its claimed 0-62mph time of 6.7sec.

Scrolling through the various driving modes alters the acoustic qualities quite markedly. In Comfort, the exhaust note is nicely subdued and distanced from the cabin. Switch into Sport, though, and it becomes instantly more determined in nature, with a raspy timbre under load and the odd crackle on a trailing throttle serving to engage enthusiast drivers.

The action of the gearbox, which can be controlled via steering wheel-mounted shift paddles, is quite decisive on upshifts. However, it's sometimes caught out as you step off the throttle in automatic mode, leading to the odd less-than-smooth downshift as you brake to a halt for traffic lights. With quite long gearing, it also helps endow the GLA 250 4Matic with a reasonable,



Off-road mode gives four-wheel-drive models decent capability in the rough

if not outstanding, combined fuel economy figure of 40.9mpg.

It's the chassis and the improvements that Mercedes' engineers have brought to the ride and handling that really stand out, though. The basis for this is the updated MFA platform, which brings increased rigidity and stiffness, as well as a decision to provide all new GLA models with a suspension featuring a combination of MacPherson struts up front and multi-links at the rear, together with optional adaptive damping control.

Along with the 30mm increase in the wheelbase, the tracks have also been widened by 36mm at the front and 46mm at the rear, giving

the new GLA a larger footprint than its predecessor and, in combination with increased volume to the wheel houses, the ability to offer a wider range of alloy wheel sizes, from the standard 17in up to 20in.

To this, the GLA 250 4Matic adds a reworked multi-plate-clutch four-wheel drive system with electromechanical instead of the earlier hydraulic operation, as well as fully variable apportioning of power to each axle depending on prevailing grip levels. In Comfort and Eco modes, the drive is distributed in a nominal 80% front, 20% rear split, while in Sport mode it's set up to deliver a more rear-biased (30% front, 70% rear) apportioning of drive. In



TESTER'S NOTE

Mercedes makes a big play of its driver assistant systems, claiming class-leading technology in this respect for the new GLA. However, the standard Active Brake Assist and Active Lane Keeping systems are overly intrusive. They often trigger the brakes, introduce steering wheel input and sound an alarm when it's not required. **GK**



The GLA is very refined with a quiet, compliant ride, even on optional 20in alloy wheels

VARIATIONS ON THE GLA THEME

The new GLA will be offered in seven different model variants with both front- and four-wheel drive from the beginning of sales. But there are more to come.

The petrol-electric plug-in hybrid GLA 250e EQ Power is due on sale by the end of this year, running a 1.3-litre four-cylinder turbo engine and an electric motor for a total 250bhp and 332lb ft. Also set for UK sale is the GLA 35 4Matic+ and GLA 45 4Matic+ from Mercedes' AMG performance car division. Both run a heavily reworked version of the GLA 250's turbocharged 2.0-litre four-cylinder petrol engine. This makes 302bhp and 295lb ft in the GLA 35, while the GLA 45 has 316bhp and 369lb ft or an even stronger 387bhp and 354lb ft in its range-topping S guise.



“ There is an ease to the driving that makes it very appealing from an everyday point of view ”

A commanding driving position enhances the GLA's crossover billing; cabin has an appropriately premium feel

Off-road mode, it offers and evenly balanced 50/50 front/rear split.

The on-road character alters quite a bit depending on the driving mode, giving the new GLA a broader range of qualities than before and the sort of cross-market appeal it is going to need to launch a greater challenge to its premium-brand rivals.

The weighting of the electromechanical steering is quite light, but there's precision to its action, even if it fails to impart much in the way of genuine road feel.

Despite its raised ride height, the GLA 250 4Matic also manages fine body control and engaging agility. Quick directional changes are met with progressive movements and

excellent levels of grip. There's a sheer ease to the driving that makes it very appealing from an everyday point of view.

With a good degree of spring travel and the optional adaptive damping the ride is fairly compliant, even with the largest wheel choice and 225/45 R20 Bridgestone Alenza tyres of our test car. Road noise is also well isolated from the cabin. In fact, overall refinement has been greatly improved, making for more enjoyable long-distance travel.

The G in the GLA name stands for the German word Gelände, meaning terrain. And having experienced the new GLA away from the bitumen, we can vouch for the limited off-road

qualities of 4Matic models, which come as standard with an Off-Road Engineering Package.

The new GLA is never going to take you deep into the jungle or the desert without the benefit of proper off-road tyres and mechanical differential locks. However, the ability of its reworked four-wheel drive system to vary the amount of drive to each axle – together with a downhill speed regulation, a unique Off-road mode that alters the intervention of the anti-lock braking system, multibeam LED headlights with an integrated off-road function and a moderate amount of ground clearance – does help it go places few prospective owners are ever likely to consider.

Mercedes must be complimented on the new GLA. It's a far more rounded and complete car than its predecessor, with greater dynamism and maturity to the way it drives, a considerably richer and roomier interior and improved levels of versatility and quality throughout.

However, we suspect the ownership experience will hinge greatly on the drivetrain. In four-wheel-drive GLA 250 guise, it's convincingly powerful and punchy, with distinct sporting qualities. But we'll need to spend time in more affordable front-wheel-drive models before we can say if the new GLA has truly hit the target.

GREG KABLE



Rear bench seat that slides 140mm forwards and backwards is an option



MERCEDES-BENZ GLA 250 4MATIC

Second-generation crossover is a far more complete and likeable offering than its predecessor



Price	£37,700 (est)
Engine	4 cyls, 1991cc, turbo, petrol
Power	222bhp at 5500rpm
Torque	258lb ft at 1800-4000rpm
Gearbox	8-spd dual-clutch automatic
Kerb weight	1525kg
0-62mph	6.7sec
Top speed	149mph
Economy	40.9mpg
CO ₂ , tax band	163g/km, 37%

RIVALS Audi Q2 40 TFSI quattro, BMW X2 xDrive20i

TESTED 18.3.20, SURREY ON SALE APRIL PRICE £33,095-£37,795 (2.5 PHEV)

FORD KUGA

All-new version of Ford's best-selling SUV, tested here in plug-in hybrid guise, marries Focus-like dynamics with SUV practicality





It's fair to say the Kuga has always been a bit of an SUV slow burner. The original, launched in 2008, looked great and steered more sweetly than the competition yet it failed to sell strongly. The second-generation Kuga arrived in 2013 and was a product of the global 'One Ford' policy that meant it had to work as well in New York as it did Neasden. It grew in size but retained its predecessor's ability to entertain its driver. After a slow start, sales took off and, in its last couple of years on sale, it hit its stride, becoming Ford's best-selling SUV.

So there's quite a bit resting on the latest version. New from the ground up, it's arguably the most ambitious iteration yet. Not only does the Kuga take a different design approach from its forebears, but it also features Ford's broadest range of powerplants yet, including petrol, diesel, mild-hybrid diesel and, here, petrol plug-in hybrid.

It's also bigger and more spacious than before and packs all the latest showroom lures, including semi-autonomous

driving modes in the form of adaptive cruise control and steering assist. There's cutting-edge connectivity and a healthy smattering of TFT screens, too. Yet despite all of this, the Kuga is a claimed 80kg lighter than its similarly specified predecessor.

In the case of this plug-in hybrid version, that's harder to verify, because there's no direct comparison, but at 1844kg, it's 50kg lighter than a Mitsubishi Outlander PHEV. It's still no lightweight, but that's not bad given how much is packaged beneath the all-new skin.

Powering this plug-in version is a variant of the Atkinson-cycle 2.5-litre petrol four-pot already seen in the Ford Escape, which was the North American version of the previous Kuga. Mated to what is essentially a CVT gearbox (see box, overleaf), it's boosted by an electric motor fed by a 14.4kWh lithium ion battery. The power output is 222bhp (petrol 113bhp, electric 109bhp) and the electric motor can propel the Kuga at up to 85mph and for up to 35 miles →



“
It delivers Ford’s trademark blend
of comfort and control as you
slice cleanly from bend to bend
”

Roomy cabin shares much with the Focus and is well equipped but it falls short of a premium feel

← before internal combustion takes over or you can find a recharging point. (You’ll need six hours from a domestic supply for a full charge.)

In operation, it’s remarkably effective, the transition between the different motive forces proving smooth and almost inaudible. You can run in pure EV mode, or leave it in Hybrid and let the computers work out what’s best. Engage Sport and you summon the combined efforts of petrol and electricity for maximum performance.

Even then, though, the Kuga

is brisk rather than quick, being outgunned by the similarly powerful Vauxhall Grandland X Hybrid. Ford claims 9.2sec for the 0-62mph sprint, but the linear nature of the gearbox means it never feels that fast or responsive. Only when you require some rapid mid-range muscle for overtaking does the Kuga feel really lively, the electric motor delivering a helpful burst of torque.

However, refinement is excellent, particularly in EV mode. And when the traditional engine does cut in, you only notice its subdued efforts when

it’s worked hard. The sense of calm is enhanced by low levels of wind noise (there’s special acoustic glass for the windscreen) and suspension that reduces even big impacts to nothing more than a muffled thump.

The Kuga is underpinned by the same C2 platform that’s used on the Focus. There are struts up front and a multi-link rear axle, while ST-Line versions like our test car get subtly stiffer springs and dampers. Yes, it’s taller than a Focus, but it’s 20mm lower than the old Kuga and sits on a track that’s 44mm wider, plus

the batteries are located as low and centrally as possible.

Add all this together and you get an SUV that handles with impressive poise and agility. In fact, it feels like what it is: a slightly higher and heavier Focus. As ever with Ford, it’s the damping that impresses the most, the Kuga breathing with the surface, delivering that trademark blend of comfort and control as you slice cleanly through one bend after another. Sharp ridges and deep potholes can cause a shudder through the cabin but otherwise the Puma rides with suppleness.

The light, electrically assisted steering is far from chatty, but it’s quick and accurate, the Kuga diving for apexes with surprising zeal. Of course, it lacks the smaller Puma’s sense of agility and adjustability but it’s not far behind and there’s genuine poise through quick corners. It’s certainly a more entertaining choice than the Grandland X or Outlander. Only when pushing on through tighter bends does the car’s mass start to tell, with over-ambitious entry speeds giving the torque vectoring system a real workout as it struggles to maintain your chosen line.

Another niggle is the braking system, which lacks a totally smooth transition between its regenerative and friction systems, so you need a delicate foot to avoid jerkiness.

While the Kuga has retained



Latest Kuga has a softer, more rounded appearance and is 20mm lower than its forebear



TESTER'S NOTE

The majority of Kuga models are front drive, with four-wheel drive available only as an option on models with the 187bhp 2.0-litre diesel. **JD**



What it lacks in outright pace, it makes up for in refinement and mid-range response is strong

the well-judged ride and handling balance of its forebears, it looks noticeably different. Gone are the angles and sharp creases, replaced by softer, more rounded lines. The similarities to the smaller Puma are obvious and, if the slightly bulbous new car isn't as handsome as before, then it's certainly distinctive, particularly with this ST-Line's colour-coded wheel-arch extensions and 18in gunmetal grey alloy wheels.

As with its predecessor, there's a heavy Focus theme inside. The dashboard is carried over largely

unchanged, complete with the same simple-to-use Sync touchscreen, which is installed with the FordPass Connect app that allows you to remotely access and monitor the car's functions from your phone.

There's a TFT instrument cluster ahead of the driver that changes its 'theme' depending on the selected driving mode, the choices of which are Comfort, Sport, Eco, Slippery and a pseudo off-road setting.

Yet while it looks the part, the smartly designed interior still falls short of that premium ambience

Ford has been striving for. Most of the materials look and feel good, but there's too much hard and scratchy plastic lower in the cabin. Still, you sit high behind the wheel, with good visibility ahead. Rear visibility isn't quite as good, with the thick C-pillars limiting your over-the-shoulder view.

In the rear, there's now a split folding bench that can slide back and forth by up to 150mm. With the seats pushed back, there's loads of room to stretch out, yet the boot can still accommodate 411 litres in the plug-in or 475 litres in other models. Slide the

rear bench as far forward as it will go and there's up to 645 litres, or 581 litres for the plug-in.

As for pricing, the plug-in Kuga is pretty much on the money with its rivals, with Titanium models starting at a competitive £33,095 and rising to £37,795 for the Vignale. We suspect the cheaper petrols will be the pick of the line-up, but the plug-in makes a strong case against its less entertaining rivals from Vauxhall and Mitsubishi.

JAMES DISDALE
@jamesdisdale

GEARBOX ENABLES TWO HYBRID MODES

Most hybrid models favour an auto or dual-clutch transmission, but Ford has developed its own 'Power Split' system. Essentially, it's very similar to the simple yet effective set-up that Toyota has been using in the Prius for years.

Commonly referred to as a CVT, it actually uses a compact planetary gearset sandwiched between a pair of motor/generator units that are mated to the internal combustion unit. This allows the Kuga to operate as both a series and a parallel hybrid.

In the parallel hybrid mode, the wheels can be driven by the electric motor, the petrol motor or both together, while in series hybrid use, it can run the petrol unit independently of road speed to charge the batteries or cut in to provide motive power as necessary. Finally, it can use the electric motor to double as a starter for the petrol engine.

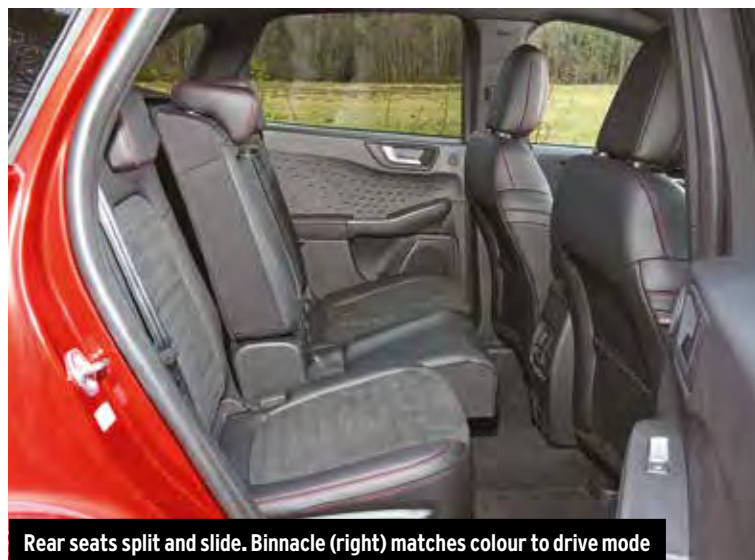

Rear seats split and slide. Binnacle (right) matches colour to drive mode



FORD KUGA 2.5 PHEV ST-LINE

Kuga has lost none of its dynamic flair yet it is now more refined and practical than ever



Price	£35,195
Engine	4 cyls, 2488cc, petrol, plus electric motor
Power	222bhp (total system output)
Torque	na
Gearbox	CVT
Kerb weight	1844kg
0-62mph	9.2sec
Top speed	124mph
Economy	201.7mpg
CO₂, tax band	32g/km, 12%
RIVALS	Mitsubishi Outlander PHEV, Peugeot 3008 Hybrid, Vauxhall Grandland X Hybrid



TESTER'S NOTE

The Taycan Turbo is more slippery than the S, with the drag coefficient down from 0.25 to 0.22. That puts it among the most aerodynamically efficient production cars on sale. **LA**



TESTED 23.3.20, SURREY ON SALE NOW

PORSCHE TAYCAN TURBO

Will the UK's narrower, bumpier roads put this 671bhp electric Porsche in its place?

This, allegedly, is the year of the electric car. "Wait, wasn't that last year, or the year before?" I hear you cry. Well, this time, we're inclined to believe it.

Or rather we were, were it not for this global pandemic forcing mass factory shutdowns and sending car company shares plunging at an alarming rate.

This is the first year that new EU corporate fleet average emissions targets come into play, prompting certain manufacturers to flood the market with the lowest-CO₂-emitting cars possible (namely, EVs and plug-in hybrids) to help avoid hefty fines. Yet estimates for new car sales in the coming months are bleak at best, and understandably so, which could put some makers in difficult situations.

But, hey, there's enough doom and gloom around these days. The new, all-electric Porsche Taycan is finally here, on British roads, and that's something to celebrate, if our verdicts from launches abroad (remember going abroad?) are anything to go by.

Having most recently driven the

current 'base' Taycan – the 4S – and with a Turbo S set to undergo Autocar's full road test treatment in the coming weeks, we find ourselves sliding behind the wheel of the middling Turbo. Not that 671bhp and nearly £116,000 really justifies the use of the term 'middling'.

Customers for a car in this price range – people who are unlikely to

baulk at the £23,000 jump from Turbo to Turbo S – may see the 81bhp deficit between this and the S as substantial. But, actually, both cars reserve this maximum power rate for full-bore launch mode. In normal driving, both Turbo and Turbo S make an identical 617bhp.

Certainly, there wasn't a single second during our four-hour drive

around south-east England's most enjoyable Tarmac when the power reserve wasn't ample to the point of being excessive. Of course, being battery powered, the pick-up is instantaneous and relentless in any situation, but unlike some EVs, there doesn't seem to be any let-up at higher speeds. Be in no doubt that only a handful of road-legal cars could keep up with the Taycan Turbo in the real world. Launch control (Sport Plus, left foot hard on brake, right foot on throttle) brings full power and ensuing seat-pinning hilarity.

Porsche has also engineered in some motor whirr to stimulate the ears under acceleration, but the optional Electric Sport Sound (standard on the Turbo S) dials it in further with some sci-fi whooshing and power-up noises. This may sound cringeworthy, but actually it adds an appealing aural reference as the numbers come thick and fast on the dials. So it's a Tesla beater in a straight line. We knew that already, but where Porsche carries



It rides typical UK roads in a well-disciplined and largely jolt-free manner



Taycan doesn't feel like a 2305kg car from the driver's seat, helped by clever chassis tuning and quick steering



Taycan Turbo can cover ground at a ferocious pace, with an instant 627lb ft on tap and four-wheel drive

Only a handful of road-legal cars could keep up with a Taycan Turbo in the real world

the baton farther than EV rivals is in the Taycan's chassis tuning. It's reassuring to know that the remarkable blend of cornering composure and usability rings true even on pockmarked UK Tarmac.

Let's start with ride comfort, which sits somewhere between the plushness of a Panamera and the purposeful firmness of a 911. In normal mode with the adaptive air suspension at its softest, it does a passable impression of an executive saloon, and although really battered surfaces still send the odd jolt through the body, it's less unsettled than a Mercedes-AMG E63. With the 20in wheels and Michelin Pilot Sport 4S tyres of our test car, road noise is also much more subdued than a 911, for example.

But, crucially, is the Taycan a

sports car? It's certainly the most dynamically convincing four-seat EV we've driven. It takes 10 minutes on a favourite B-road to discover what an unprecedented job Porsche has done in disguising the Taycan's 2.3-tonne kerb weight. It feels lighter on its feet than a Panamera, despite being 300kg heavier, with sharp turn-in and unflappable body control.

Our car has optional Dynamic Chassis Control, bringing active roll stabilisation, which probably helped matters. Only extreme direction changes reveal the substantial weight transfer in action. The torque-vectoring four-wheel drive also makes traction nigh-on impossible to break on the road, although there's a welcome sense of rear-biased power delivery on the exit of corners.

The steering feels quick but not

darty, and weighty but consistent. Forward visibility is excellent (although rearward visibility isn't great) and the driving position spot on. Even brake pedal feel is largely good. The coasting regeneration is relatively mild because Porsche wants driving the Taycan to be a two-pedal experience. No, it isn't as much fun as a 911, but for it to be so close to a car more than three-quarters of a tonne lighter is extraordinary.

The Taycan is also (smallish boot aside) perfectly usable family transport, with ample leg and head room for two adults in the rear. The interior is as well finished as it should be for the price and it takes little time to get used to the dual-screen dashboard layout.

The only area in which the Taycan isn't top of the EV tree is range – crucial for many. Its 800V tech means an 80% charge is possible (with a rare 350kW charger) in as little as 22 minutes, but while the Turbo's quoted 279-mile figure isn't bad, the Tesla Model S Performance claims to go 88 miles further on a charge.

LAWRENCE ALLAN

[@loballan](#)



PORSCHE TAYCAN TURBO

The new benchmark for electric performance saloons. Only the price and so-so range hold it back

★★★★★

Price	£115,858
Engine	Two electric motors
Power	617bhp (671bhp on 'overboost')
Torque	627lb ft
Gearbox	Single-stage transmission (front), dual-speed (rear)
Kerb weight	2305kg
0-60mph	3.0sec
Top speed	161mph (governed)
Battery	93.4kWh
Range	279 miles
CO₂, tax band	0g/km, 0%
RIVALS	Mercedes-AMG GT 4-Door Coupé, Tesla Model S

TESTED 22.2.20, SURREY ON SALE NOW

BMW M8 COMPETITION COUPE

Big-hitting all-rounder lacks the single edge it needs over rivals on UK roads

This feels like the 'right' M8 to me. The coupé, here driven in the UK for the first time. It's smaller and lighter than a four-door Gran Coupé and less floppy than a Convertible.

And two fewer doors than an M5, with which this large 'M' platform otherwise shares a good amount – the same 616bhp 4.4-litre V8 and automatic four-wheel drive. Which can also be put into rear-drive. Goody.

BMW's big platform underpins 5, 7 and 8 Series but the M8 coupé has a shorter wheelbase than the M5, sits 10mm lower and is firmly sprung to keep hold of its 1885kg.

There's a 38mm wider rear track and, underneath, subframes are more firmly attached to the shell – so this is a more rigid car; more suited, you'd argue, to being a super-GT.

That, and its price, plus the fact that it's the fastest BMW ever, gives it a vast array of rivals; everything from a Porsche 911 to a Bentley Continental GT (I've tested it against both on video, online this week), via the Mercedes-AMG GT, Audi R8 and even McLaren GT.

In essence, it's a 2+2 that's meant to do everything. A daily car designed to entertain, up to and including going on a race track. With a 0-62mph time of 3.2sec, a (delimited) top speed of 190mph and optional carbon-ceramic brakes, it has the credentials for a track, though I think an M8 Competition (there's a less hardcore non-Competition one available overseas) would be surprised to find its owner had taken it to one.



M8 impresses at speed; two red buttons on steering wheel are for driving modes



Inside, the M8 is thoroughly well finished; sumptuous and comfortable but with a bewildering array of driving mode controls, as if BMW and Mercedes-AMG are competing to see which can create this year's most baffling cabin. Familiarity helps a little and there are two red buttons on a busy steering wheel to programme your preferred modes. I suspect after a few weeks of trial and error you'll find one that works as your base mode and another for occasional faster driving.

The M8, despite its girth, is more impressive during the faster stuff. As well as the 616bhp, the engine makes a flat 553bhp figure all the way from 1800-5800rpm. At a test track, the car's inherent pace was evident. It doesn't feel quite as urgent as its headline acceleration time suggests but I think that's down to the soft, big-boosting nature of its performance. It grips brilliantly, starts to slide and then has the security of four-wheel drive to pull it straight easily (or, in rear-drive

mode, it has all the scope you need to murder the rear tyres in short order).

On the road, the M8 is an agreeable companion. Unlike most of its rivals, you can, at least, get a couple of people in the back (they'll complain less than they would in a 911, though wouldn't want to be there too long) while there's a decent boot, too. But for practicality, which could be a deal breaker, the M8 doesn't have the ride deftness of the best GT cars. A 911 is no less comfortable, although it is less spacious and noisy. But it drives with so much more agility and poise you'd forgive it that one thing, given the BMW doesn't pull out a strong comfort advantage.

In fact, the lesser 850i is a more pleasing every-day car, a better GT that's more comfortable and has no little poise itself. As speeds rise, the M8 Competition doesn't truly satisfy like a sports car to set it apart from this or its rivals, either. It lacks the steering feel of a 911 or the agility of an R8, or the brute muscle car

character of a Mercedes-AMG GT. I like it a lot in isolation but, when it comes to it, would sign elsewhere.

MATT PRIOR

[@matty_prior](#)

BMW M8 COMPETITION COUPE

Tries to do all things, having grand touring and sporting behaviour, but is ultimately compromised on both

★★★★☆

Price	£123,435
Engine	V8, 4395cc, turbocharged, petrol
Power	616bhp at 6000rpm
Torque	553lb ft at 1800-5800rpm
Gearbox	8-spd automatic
Kerb weight	1885kg
Top speed	155mph (190mph delimited)
0-62mph	3.2sec
Economy	25.4mpg
CO ₂ , tax band	242g/km, 37%
RIVALS	Audi R8, Mercedes AMG GT



TESTER'S NOTE

There are some 12 different M models on BMW's website. I understand why, but wonder if fewer, better ones would be good for us, if not the bottom line. **MP**



**TESTER'S NOTE**

Lamborghini's new sports seats cost a whopping £6156 but are a game-changer for a brand that has never matched Ferrari or Porsche when it comes to positioning the driver. Gone is the awkwardly perched sensation and there's more leg room than before. The Evo now feels like a supercar as well as looking - and going - like one. **RL**



TESTED 21.3.20, BEDFORDSHIRE ON SALE NOW

LAMBORGHINI HURACÁN EVO RWD

New rear-wheel-drive version is the cheapest Evo and, for keen drivers, the most fun

Lamborghini likes to keep us waiting for the sweetest derivative of its entry-level supercar. It's a cruel habit, and one that took root in 2009 with the much-loved Gallardo LP550-2 Balboni, which arrived a mere six years after the original 'baby Lambo'. There was then a delay of two years between the Huracán LP610-4 and the far better LP580-2. And now, only after the coupé and Spyder versions of the widely revised Huracán Evo have enjoyed generous head starts, Lamborghini has presented its latest potential gem: the Huracán Evo RWD.

As the name suggests, and as formerly denoted in Lamborghini nomenclature by '2', this is a rear-wheel-drive model. It is also now the most attainable rung on the Huracán ladder, costing £34,000 less than the 'normal', four-wheel-drive Evo. At £164,000, the RWD is priced closer to the £149,000 McLaren 570S than Ferrari's £203,500 F8 Tributo, but there are some eye-watering options. The transparent engine cover alone costs £4860, while composite brake discs will set you back £5412 and a DAB radio an indefensible £648.

What you lose, apart from the front driveshafts, is the standard Evo's four-wheel steering and torque-vectoring electronics. You also lose 33kg from the kerb weight and 29bhp from the howling 5.2-litre V10, which is otherwise transplanted directly from the bowels of the outgoing Huracán Performante. It's a nominal decrease in power, and one designed to usher more suggestible customers towards the more expensive four-wheel-drive Huracán. For the rest of us, the RWD's 602bhp, 413lb ft and 0-62mph time of 3.3sec (versus 2.9sec for the regular Evo) are more than enough to be getting on with.

The RWD is also the finer driver's car. When combined, the sound and the performance are as giddily pulverising as ever, and even without four-wheel drive, there's never any issue with straight-line traction, at least on dry roads. All you ever hear about is this magnificent engine's top end, but so big are its lungs that you'll have left almost anything else for dead by the time the needle has even reached 4000rpm, and from then on things only get wilder. It's one of the greatest road car engines ever built.

The dual-clutch gearbox is another highlight, and the paddle shifters are a joy to use, being nicely weighted and enacting ultra-quick changes. As a method of reloading the engine for another surge to the 8500rpm redline, this takes some beating.

Equally, if you want to lope about in Strada mode, with the dampers usefully softened off (Sport remains marginally too firm for the road, and Corsa is straight-up brittle), this 'box goes about its business gently, leaning on the engine's torque. In fact, drivability at low speeds is excellent.

But by far the best thing about the RWD is that where the regular Huracán must be driven at breakneck speed to express itself, this car flows more sweetly at sensible speeds and feels less frenetic. Without rear wheels that swivel, the steering rack can feel lazy mid-corner, but without the corruption of driveshafts, its initial travel is cleaner and lighter, and less unsprung mass means the front axle also rides bumps in the road more fluently. Better still, with nothing pulling the car's nose along, there's more of a squatting sensation at the rear through corners. Technically,

this is less desirable than a perfectly flat body, but it feels far more satisfying. Really chase throttle and you'll also get the rear tyres ever so slightly over-rotating with a delicacy that's beyond the regular Evo.

Equally, there's so much grip that for outright oversteer you need to provoke the car and use some weight transfer; and if the RWD has a vice, it's that the tail can snatch wide sharply and requires concentration to catch. The F8 Tributo is more playful and forgiving in this sense and, just maybe, a little less authentic.

That's the thing about this latest Huracán: beyond the noise and performance, it's more gritty and involving than typical Lamborghini fare, and the additional polish in the steering and handling add up to something special.

RICHARD LANE

[@_rlane_](#)

LAMBORGHINI HURACÁN EVO RWD

The most involving car Lamborghini makes and genuinely good to drive but still short of the best from Ferrari



Price	£164,400
Engine	V10, 5204cc, petrol
Power	602bhp at 8000rpm
Torque	413lb ft at 6500rpm
Gearbox	7-spd dual-clutch automatic
Dry weight	1389kg
0-62mph	3.3sec
Top speed	202mph
Economy	20.5mpg
CO₂, tax band	330g/km, 37%
RIVALS	Audi R8 RWD, Ferrari F8 Tributo, McLaren 570S



RWD is more enjoyable at road speeds than the four-wheel-drive Evo and it still feels suitably supercar inside



TESTER'S NOTE
Imagine the serenity of a Bentley Mulsanne paired with the silent running of a Tesla Model S. In effect, that's what you get with this A8. **NW**



TESTED 23.3.20. SURREY ON SALE NOW

AUDI A8 L 60 TFSIe

Does petrol-electric power elevate Audi's luxury limousine to an even higher level?

This might come as something of a surprise, but if we had to pick a car that best demonstrates the virtues of electrification, this new Audi plug-in hybrid might be it. Why? Well, judged solely on what a luxury limousine needs to deliver, namely supreme refinement and smoothness for passengers and low running costs for the owner, the A8 60 TFSIe isn't simply on par with its petrol and diesel siblings but better.

Then again, it should be. BMW and Mercedes-Benz have offered plug-in hybrid versions of their largest limos for a couple of years already, giving the engineers at Ingolstadt something to aim for as well as the opportunity to make use of the newest hybrid technology available.

That technology includes a 126bhp 'permanently excited' electric motor (like in the electric Porsche Taycan), which is paired to a 335bhp 3.0-litre turbocharged V6 petrol engine. Their combined output of 443bhp is sent to all four wheels through an eight-speed automatic gearbox, resulting in pretty punchy performance.

The 0-62mph sprint takes just 4.9sec (quicker than both the 745Le and S560e L) and it's able to accelerate up to an electronically limited 155mph on the autobahn.

But with most 60 TFSIes destined to spend life ferrying high-flying execs around cities, we suspect that a 28.6-mile electric range (compared with 28-31 for the BMW and 25 for the Mercedes) will be of more interest to buyers than outright performance.

Indeed, with its 14.1kWh battery fully charged, this A8 to all intents and purposes functions just like an electric car, with its motor producing enough poke for most situations. It can even reach 84mph on electricity alone, making for a beautifully serene experience for passengers, with no engine noise or jerky gearchanges disturbing the relaxed ambience.

When the V6 does eventually kick in, the transition from electric to petrol power is almost undetectable. This, combined with a distinct lack of wind noise, makes the way the car accelerates somewhat deceptive; it gains speed like an A380 at take-off.

However, with that big battery on board, the 60 TFSIe is unsurprisingly not exactly a driver's car. It wallows a bit through bends on its standard air suspension, its steering is accurate but devoid of feel and its brakes can be a little inconsistent in their operation. It's a car that wants you to drive like a chauffeur – so much so, in fact, that it will even give you lessons.

Predictive sat-nav data is used to help you manage the battery's charge, so you'll receive plenty of electrical assistance on a shorter journey but more help from the petrol engine on a longer one. The accelerator pedal will even nudge your right foot when you're approaching a lower speed limit to remind you to lift off so that juice can be sent back to the battery; the system can recover 25kW from coasting and 80kW from the brakes.

This is a cleverly calibrated system that not only improves electric range but also makes you a smoother driver, benefiting your passengers. And this being an A8, they should already be very relaxed, thanks to the all-round plushness and acres of leg room.

So, should your A8 be a plug-in hybrid? That depends on how you'll use it. If you cover many motorway miles, go for a diesel, because you won't reap the benefits of the electric element. But if you spend a lot of time in town, the 60 TFSIe is a no-brainer. As well as being smoother than the diesel, it's quieter than a pair of Bose noise-cancelling headphones and very frugal; we saw more than 100mpg on our inner-city test route.

Plus, with that 28.6-mile electric range and an official CO₂ rating of just 60g/km, it makes for a relatively cheap company car and is exempt from London's congestion charge.

If figures like those don't clearly demonstrate to you the virtues of electrification, we can't see what will.

NEIL WINN
@nwinn86

AUDI A8 L 60 TFSIe

Even placing aside its frugality, this hybrid feels like far more of a luxury product than its diesel range-mate



Price	£88,195
Engine	V6, 2995cc, turbo, petrol, plus electric motor
Power	443bhp (combined)
Torque	516lb ft (combined)
Gearbox	8-spd automatic
Kerb weight	2330kg
0-62mph	4.9sec
Top speed	155mph (governed)
Economy	108.6mpg
CO₂, tax band	60g/km, 15%
RIVALS	BMW 745Le, Mercedes-Benz S560e L



Ride is a little lumpier but still supple; interior is plusher than rivals'

**TESTER'S NOTE**

The boot may be much less practical after the soft-top conversion, but there is at least a hatch with remote openers to enable the through-loading of longer items. **GK**



TESTED 17.3.20. MUNICH, GERMANY ON SALE NOW

VOLKSWAGEN T-ROC CABRIOLET

New model is Volkswagen's only convertible and the sole soft-top crossover on sale

Adding handsomely to the weight, reducing the structural rigidity and compromising the versatility of one of the most popular crossovers around doesn't sound like a clever idea. But that's exactly what Volkswagen has done.

The new T-Roc Cabriolet indirectly replaces the Golf Cabriolet and, with the Beetle now also gone, that leaves it as the brand's sole open-top model.

The styling remains well balanced when the hard top is in place; it's a multi-layer fabric structure designed to mimic the lines of the fixed-roof T-Roc. To package it, VW has made some notable changes to the platform, the most significant of which is the addition of 37mm to the wheelbase, in turn adding 34mm to the overall length. There's also a raft of extra strengthening measures in the floorpan, sills, doors and windscreen.

These underbody changes create one big drawback: the car tested here weighs almost 200kg more than its regular equivalent, and it struggles to hide that heft. The turbocharged

1.5-litre four-cylinder petrol engine, with 148bhp and 184lb ft of torque, is terrifically flexible and quite willing to rev, but it has to work harder while on the move and demands more gearchanges to achieve this.

Despite firm damping, the T-Roc Cabriolet doesn't like to be pushed too hard, either. Body roll is pretty well controlled – there's a lower centre of gravity, due to the lighter roof and added weight concentrated within the platform – but flex and shake are quite noticeable, especially on less-than-smooth surfaces, limiting the ride and handling.

It's not all bad, though, because adopting a more moderate speed and lowering the roof gives the T-Roc Cabriolet a chance to display more favourable traits. It's very much in its element at a gentle cruise, even if the effect of flex and shake never really disappears completely. The seven-speed dual-clutch automatic would be our choice, but the six-speed manual is light and precise in action.

The swift operation of the roof,

which retracts and hides above the cargo area in just 12sec, provides an al fresco experience at the press of a button. With the windows up, there's very little wind buffeting up to around 80mph, making it quite pleasant as long as the road isn't too challenging and the weather is right. Still, it's unusual. Forget any notion of sportiness: you sit at SUV height, just without a roof over your head.

The cabin mirrors that of the usual T-Roc, with a hard plastic dashboard and a mix of precise controls and inoffensive but not exactly luxurious trim materials. You can choose Active Info Display digital instruments as part of a long list of options, which also includes an excellent infotainment system and the well-bolstered sports seats of our test car.

The driving position immediately feels more intimate than is usual in the T-Roc, due to the extra rake of the windscreen and proximity of its header rail, which sits uncomfortably close within your peripheral vision. It's better, then, to lower your seat.

The problem with that, however, is you then find yourself enclosed in a car that has a relatively high shoulder line, shallow glass and a high rear, making visibility a key weak point.

The open-air experience doesn't come without compromises in other areas, too. When down, the roof robs the boot of space and versatility. It shrinks from 445 litres in the regular T-Roc to 284 litres, while the narrow aperture restricts bulky item loading.

It's easy to see why the T-Roc Cabriolet might tempt some buyers. From the outside, it promises the best of both worlds: the versatility of an SUV and the open-air driving appeal of a convertible. But the reality is that it's compromised on both fronts.

GREG KABLE

VOLKSWAGEN T-ROC CABRIOLET 1.5 TSI EVO DESIGN

Limited in terms of ride and handling by its porkiness, and loses a fair deal of versatility from the regular T-Roc



Price	£28,525
Engine	4 cyls, 1498cc, turbocharged, petrol
Power	148bhp
Torque	184lb ft at 1500-3500rpm
Gearbox	6-spd manual
Kerb weight	1524kg
0-62mph	9.6sec
Top speed	127mph
Economy	44.0mpg
CO₂, tax band	146g/km, 32%
RIVALS	BMW 2 Series Convertible, Mercedes C-Class Cabriolet



T-Roc cruises nicely but can flex and shake; interior is just about up to scratch



Ford Puma

Ford aims to take the crossover class by storm as it revives the Puma name

MODEL TESTED 1.0T 125 MHEV TITANIUM

Price £20,845 • Power 123bhp • Torque 155lb ft • 0-60mph 10.0sec • 30-70mph in fourth 13.5sec • Fuel economy 39.0mpg • CO₂ emissions 96g/km • 70-0mph 57.3m

Given that the Puma of the late 1990s arrived with the bold tagline 'A driver's dream', Ford's decision to reprise the name of its pint-size coupé on the tailgate of a crossover seems perplexing. With a larger frontal area, a higher centre of gravity and more weight, this new Puma clearly distances itself from traditional 'driver's dream' territory where the 1034kg original did everything budgets would allow to get closer.

But times have changed. Today, the compact crossover class is bursting at the seams with members as manufacturers cash in on demand and the mass-market space for more unusual, enthusiast-minded projects has rapidly shrunk. However, what this segment has long been devoid of is something genuinely good to drive, which is where – Ford says – this new Puma will justify its name. The car will slot into the range between the dreary EcoSport and the Kuga and it shares a platform with the Fiesta, which, as you may have heard, is easily the dynamic benchmark in the supermini class.

The Puma is the first small Ford to use hybrid power, in the form of a 48V system bolstering a three-cylinder petrol turbo engine. The car's striking design, which has been described as 'anti-wedge' by one Ford designer, is intended to steal sales from more premium brands, notably Mini. Strong ergonomics are also promised, with the Puma possessing one of the largest boot capacities in the class, more passenger space than the Fiesta and what Ford calls the Megabox, more on which in a moment. Fully digital instrument dials and level two 'autonomous' driver aids should add to its appeal.

How, then, does the second coming of the Puma measure up to the likes of the Nissan Juke, Seat Arona, Skoda Kamiq, Renault Captur, Volkswagen T-Cross and Mini Countryman? Let's find out.

DESIGN AND ENGINEERING



The Puma is built in Ford's Craiova plant in Romania and sits on the same B2 platform as the Fiesta, although this has been stretched and widened to meet the more spacious crossover brief. The upsizing is considerable, the new model being 146mm longer (95mm of which is accounted for in the wheelbase) and 71mm wider than the supermini, with track width up 58mm.

Naturally, the roofline also sits far higher, while the exterior design rivals that of the Juke for sheer individuality and references the original Puma in its slightly bug-eyed, open-mouthed face. Ford has deliberately made the car's beltline flatter than usual in an effort to keep the car's proportions balanced and less raked towards the nose, as is commonplace among rivals.

Under the bulbous bonnet is a 1.0-litre three-cylinder petrol unit

Range at a glance

ENGINES	POWER	FROM
1.0T	123bhp	£20,545
1.0T MHEV	123bhp	£20,845
1.0T MHEV	153bhp	£21,595

TRANSMISSIONS

6-spd manual

For now, the UK Puma line-up is relatively straightforward. Power comes from Ford's 1.0-litre Ecoboost petrol three-pot, which is available with either 123bhp or 153bhp. Mild-hybrid assistance is an option for the 123bhp unit and standard on the 153bhp engine. All are paired with a six-speed manual gearbox that drives the front wheels. The trim line-up is also simple: our Titanium-spec test car represents the entry level and is followed by ST-Line and ST-Line X. A diesel-powered Puma and a sportier ST performance model are in the pipeline, the latter expected to be officially revealed at some point this year.

available in the UK with 123bhp, in both non-hybrid and mild-hybrid guises, and 153bhp, in mild-hybrid form only. Ford is marketing the Puma heavily on its hybrid status. An integrated starter/generator replaces the alternator and, as well as recovering some energy during braking and allowing the car to coast with the engine off, provides torque fill for better throttle response and acceleration. The system can add only 37lb ft, so nobody should expect dramatically improved acceleration.

On a related note, with the mild-hybrid system masking lag, Ford has been able to add a larger turbo. Cylinder deactivation is then carried over from previous versions of the non-hybrid Ecoboost engine and can cut three cylinders down to two in just 14 milliseconds under light loads. A 1.5-litre four-cylinder diesel will arrive later and an ST version is mooted, but our test car is in 123bhp petrol hybrid form with a six-speed manual and 17in alloy wheels.

With its extra ride height, there is 'more' suspension than in the low-riding Fiesta, although the Puma's rear torsion beam is said to be stiffer and there are firmer suspension bushes and new top mounts. A common crossover bugbear is overly firm suspension, a result of trying to contain a taller body while cornering, so it will be interesting to see how the Puma fares in this respect as it strives for class-topping dynamics. →



Previous Ford Puma was a small coupé



● Titanium cars have these smart-looking 10-spoke 17in alloy wheels as standard. ST-Line models also get 17in alloys but in a different style, while ST-Line X cars move up to 18s.



● Headlights are standard projector units on all Puma models. However, the daytime-running lights and rear lights do make use of LED bulbs and look appealingly sharp as a result.



● Rear parking camera comes as part of the £900 Driver Assistance pack, which also adds a suite of semi-autonomous driver aids such as traffic jam assist and adaptive cruise control.



● In what is increasingly Ford's house style, the model name is sprawled across the tailgate in bold lettering, just as it is on the new Focus. We think it suits the compact crossover rather well, actually.

We like

- Practical, but genuinely rewarding to drive in any specification
- Impressively, ride quality isn't compromised in order to achieve this

We don't like

- Interior lacks design imagination, with some cheaper-looking surfaces
- Many will expect better fuel economy from a hybrid powertrain

Weights and measures

DIMENSIONS

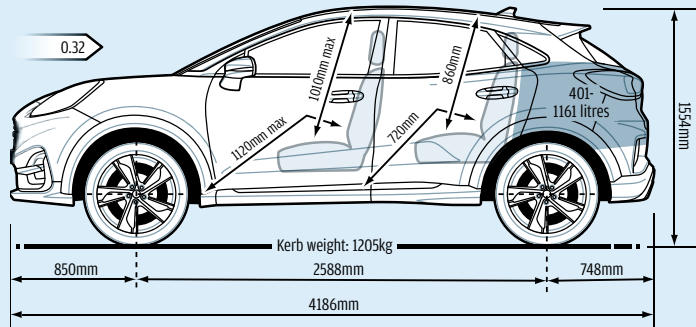

PARKING

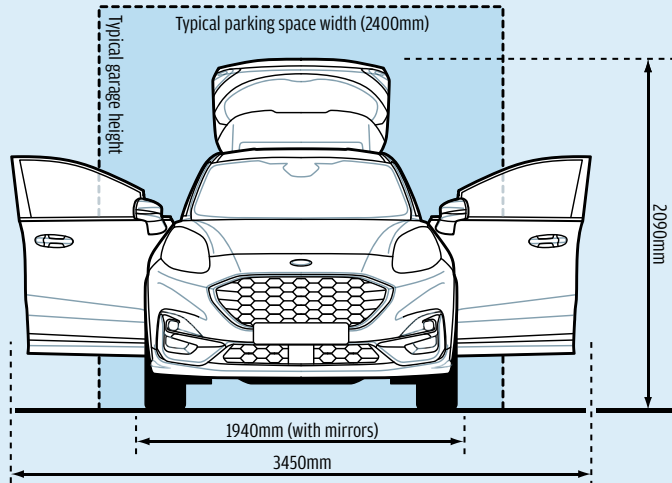

WHEEL AND PEDAL ALIGNMENT

Throttle and brake pedals could be slightly closer, but otherwise the positioning is fine. The clutch pedal's travel is fairly short, but the bite point is easy to read. The steering column's slight offset doesn't prove uncomfortable, either.

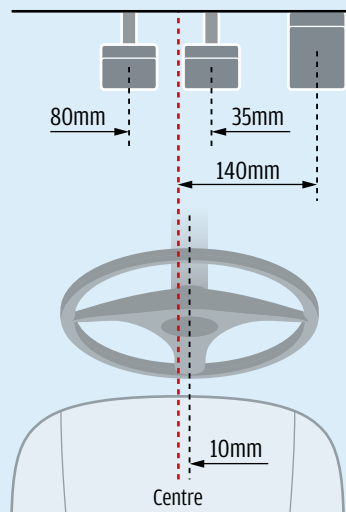

HEADLIGHTS

Beam spread and brightness when the headlights are dipped are reasonably limited but work well enough. We weren't able to try them on full beam.



● Front seats offer good lateral support. The inclusion of the £300 Comfort pack adds seat heaters and a heated steering wheel as well. Worth it in winter.



● Rear door apertures are a touch narrow but there's enough room for two adults to sit comfortably back here. Three small children should be able to fit at a push, too.

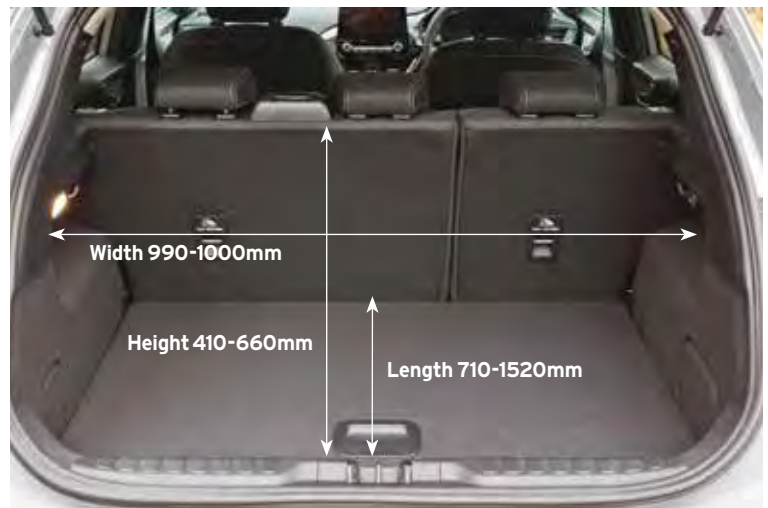

● Fold the rear seats down and you can extend the available boot space from 401 litres to 1161 litres. Back seats can split and fold through a 60:40 ratio.

INTERIOR



Ford hasn't been quite as adventurous with the Puma's interior styling as it was with its bold exterior. In fact, there's really very little about the compact crossover's cabin to separate it from any other vehicle in the Ford line-up.

Finished largely in darker shades of cloth and soft and hard plastics, it's a slightly drab environment in which to spend time. Next to the likes of the more expressive Captur, it feels decidedly ordinary, and almost ascetic when compared with the ritzy new Peugeot 2008.

But what it lacks in form it makes up for in function. There's

a wide range of adjustability in the steering column and seat base, which affords you the opportunity to sit in a marginally lower, slightly more immersive driving position than you'll find in many of its rivals. Given the Puma's heightened focus on energetic driver appeal, this flexibility is welcome.

Long gone are the days when Ford saw fit to adorn its dashboards with an almost infinite selection of tiny buttons, too. The controls for the HVAC system, heated seats and Quickclear windscreen are thoughtfully sized and spaced, while gentle blue backlighting makes them easy to read. The 8.0in touchscreen isn't quite as difficult as some systems to use on the move, either.

The manual gearshifter could sit a bit higher up and squeak a bit less when you use it, mind.

Passenger space in the second row is reasonable enough, but those sat in the back won't feel quite as separated as they might in a T-Cross or Kamiq. Our tape measure revealed 860mm of head room (the Captur we road tested last week had 920mm) and a typical leg room figure of 720mm (up to 680mm in the Renault).

In mild-hybrid guise, the Puma's boot isn't quite as capacious as it could be. The additional battery drops outright space from 456 to 401 litres with the rear seats in place (the Captur has 422 litres). Lift the boot floor, though, and you'll reveal the Puma's party piece: the 80-litre

Megabox. This hard plastic container is ideal for carrying muddy boots or sodden raincoats and comes with a plug in the floor so it can be rinsed out and drained.

PERFORMANCE



The Puma's powertrain has a downsized, turbo three-pot capable of shutting off entirely when the car's coasting; of deactivating a cylinder when running lean; and of leaning on a 15bhp, 37lb ft electric motor to boost overall efficiency, outright performance or drivability. It works really well 99% of the time to conceal the technical complexity needed to achieve all that.

It hauls the car along from →



● Drive mode selector sits on the centre console, just aft of the gearlever. Lowered position can make it a touch tricky to find on the move on first acquaintance.



● A wireless charging slot comes as standard on all Puma models. It doubles as a handy storage tray if your phone isn't compatible, too.



● Removable boot floor can be positioned so as not to sit flush with the mouth of the Megabox, liberating a storage cavity between that and the main boot space.



Multimedia system

★★★★☆

All Pumas sold in the UK have Ford's Sync3 infotainment system as standard. This comprises an 8.0in touchscreen that's used to operate effectively all of the suite's main features, which include sat-nav, DAB radio, Apple CarPlay and Android Auto.

Its responsiveness is fine but, as we've written previously, it wants for graphical sophistication - particularly in comparison to its Volkswagen Group rivals. The shortcut buttons that run along the bottom edge of the screen give quick access to all of the primary sub-menus, although physical buttons around the display's border would still be preferable.

FordConnect comes as standard across the range, too, adding a wi-fi hotspot with connectivity for up to 10 devices. Meanwhile, the FordPass mobile app includes handy features such as a vehicle locator and vehicle status checker, so you can verify the fuel level and oil status remotely, and unlock the doors as well.



“
The handling makes you question whether you're driving a crossover at all
”

◀ lowish revs with impressive responsiveness and a pleasingly accessible sense of oomph. Perhaps more important, it only allows you to become aware of the complexity of its operating brief in the most fleeting moments – sometimes with a hint of inconsistency in its braking response if you happen to knock the car out of gear early when decelerating, or with a slightly abrupt take-up of drive just as you tip into the accelerator pedal.

These are problems you'd be likely to become conscious of only if you were anticipating them, though. Considering how much it plainly does to boost low-rev torque, saving you from otherwise necessary gearchanges, the mild-hybrid system adds much more to the car's overall drivability than it detracts.

On a wet test day, the Puma took a two-way average of 10.0sec to hit 60mph from rest, a fairly strong if not

exceptional showing. But the fact that it was almost 7.0sec (or about 40%) quicker accelerating from 30mph to 70mph in fourth gear than the 1.0-litre turbocharged Juke we tested late last year illustrates the difference made by Ford's hybrid system.

When pulling from low engine speeds in higher gears, you can feel the torque it contributes quite clearly – and, if you watch the tach needle, you can also feel the point in the rev range (just above 4000rpm) when the electric motor has to switch off.

The car has a healthy-feeling outright performance level for mixed road driving and a short, pleasant, well-defined gearshift action. It's smooth enough and as powerful and stable as it needs to be, under braking, although it's easier to judge your initial pedal inputs once you've learned to squeeze the middle pedal only after you've already selected a

lower gear. It's best not to downshift in the middle of a deceleration phase where you can avoid it, since doing so interferes slightly with the regenerative braking you get from the hybrid system and spoils the initial braking response a little.

HANDLING AND STABILITY

★★★★★

The Puma was clearly intended to be a crossover hatchback that would handle before it left the designer's sketchbook. It's lower-rising and more athletic-looking than most of its class opponents and quite clearly carried certain key advantages forward into its dynamic development phase for its chassis engineers to seize on. Even so, it's remarkable how well those engineers have done and how clearly this car stands apart from its rivals in a class that has until now struggled

to produce anything genuinely appealing to drive.

Our test car had no particular advantage to its specification in this respect: it was a Titanium-trim example without the lowered sport suspension that an ST-Line would have had and its 17in rims left plenty of room to further increase the outright grip level. And yet its lateral body control and chassis response were both excellent and its steering gently meaty in its weighting and crisply incisive in its feel.

Just as the driving position seems to place you only medium-high at the wheel, so the keen, level, agile and engaging handling makes you question whether you're driving a crossover at all. The car arcs neatly towards an apex and maintains its dynamic composure and chassis balance under load and when driven quickly, and in both respects, the



● Puma feels keen, lithe and engaging in corners, especially for a crossover, yet there's no price to pay for its athleticism in its ride quality, at least in a Titanium-spec model

Assisted driving notes ★★★★★

The entry-level Titanium Puma has autonomous emergency braking, conventional cruise control and lane-keeping assist. An optional £900 Driver Assistance pack (fitted to our test car) brings blindspot warning, cross-traffic alert and traffic jam assist systems, among others, and adds 'intelligent' distance-keeping functionality to the cruise control.

The systems are generally tuned so as to be quite discreet but can, in most cases, be adjusted for sensitivity and, in some cases, deactivated completely. Even in its most sensitive setting, the lane-keeping aid keeps the driver engaged. However, it didn't always detect the bounds of a motorway lane through roadworks or in bad weather.

Our test car was able to consistently recognise posted speed limits and offered a speeding warning but couldn't adapt the car's set cruise control speed automatically. Still, for a £20k car, the Puma's assisted driving functionality is fairly extensive and impressive.

AUTOMATIC EMERGENCY BRAKING

- Does the system seem less than averagely prone to false activation? ✓
- Can it be deactivated? ✓
- Does it have pedestrian/cyclist detection? ✓

LANE KEEPING ASSIST

- Is the system tuned to keep the driver engaged at all times? ✓
- Is it adjustable for sensitivity? ✓
- Does it allow you to drive around a pothole/obstacle within your lane easily and without deactivation? ✓

INTELLIGENT CRUISE CONTROL

- Can the system consistently recognise and automatically adopt motorway gantry-signed variable speed limits? ✗
- Does it prevent undertaking? ✗
- Does it have effective audible or visual alerts, or steering intervention, to prevent changing lanes into the path of an overtaking car? ✓

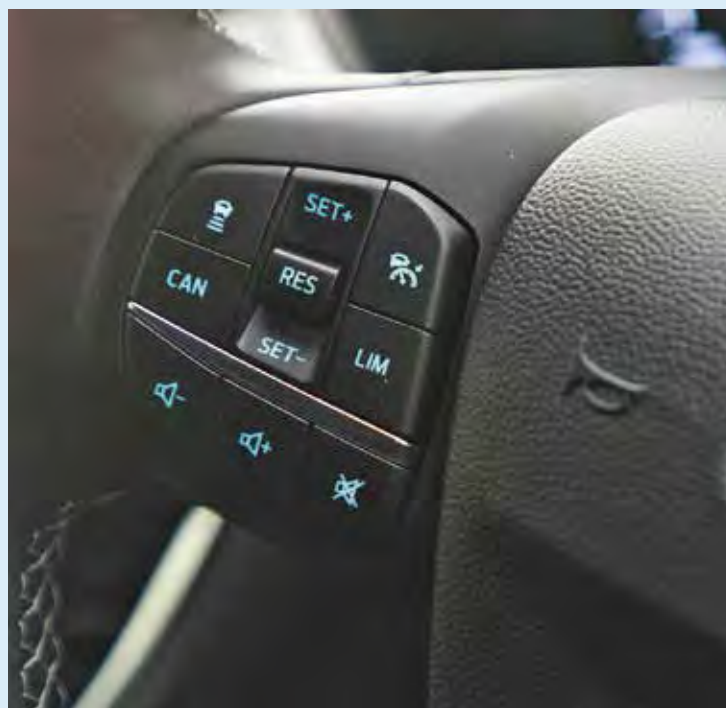

car could easily just pass for a well-sorted, athletic-feeling hatchback.

When the electronic traction and stability controls do intervene in the driving experience, they do so progressively and without intruding at first. The car only gives you the option to disable the traction control, leaving the stability aid on in any circumstances; and just occasionally, once you've really got to grips with the potential of the chassis and are at risk of actually enjoying yourself, that does seem a shame when it begins to intrude on the car's ability to entertain.

COMFORT AND ISOLATION

★★★★★

For a compact crossover so keen on entertaining with fleet-footed, spy handling responses, it's pleasingly refreshing to discover that ride refinement hasn't been sacrificed.

The impressively tuned suspension provides an enviable blend of close body control and well-mannered fluency when travelling at pace, enabling it to confidently smooth over successive low-frequency compressions.

Its low-speed ride isn't as prone to upset and agitation as the Captur we road tested last week, either. Admittedly, a T-Cross will more consistently distance you from the sorts of physical and aural intrusions that accompany runs over cratered stretches of road, but the Ford's ability to soften all but the largest impacts means it doesn't trail too far behind.

That said, it's worth pointing out, albeit briefly, that pricier ST-Line and ST-Line X Pumas aren't quite as liveable with as their Titanium range-mates. Wider test experience shows their larger wheels and stiffer sports suspension can add a degree

of brittleness into the dynamic equation, particularly around town.

At motorway speeds, the Puma's cabin is sufficiently well isolated from wind and road noise to avoid undue criticism, but it doesn't quite rewrite the playbook, either. The three-cylinder engine can also boom back into the cabin if load is applied at crank speeds below 2000rpm. Still, at a 70mph cruise, our microphone returned a 67dB reading, which is equal to the Captur's efforts.

BUYING AND OWNING

★★★★★

Although the Puma may appear an expensive option in relation to various rivals, this isn't the case. For one thing, all the available engines are strong and frugal, and for another, even our entry-level Titanium car came well equipped, with climate control and automatic

lights among the amenities included. However, to have the 12.3in digital instrument display, you'll need ST-Line trim. Forecasts also predict that the Ford will have more robust residual values than even strong rivals such as the Captur and T-Cross, and the fact that such a large proportion of the range slips under the 99g/km CO₂ threshold ought to make the Puma an attractive option for company car users.

As for fuel economy – a pivotal battleground in the family crossover class – the Puma does well without managing to be exceptional. Our 123bhp hybrid returned 50mpg on the motorway and near enough 40mpg with a mix of driving for a typical driving range of 360 miles. Big-mileage owners may benefit further from the diesel Puma, which is likely to notch up nearer 60mpg on longer routes. →

ACCELERATION**Ford Puma 1.0T 125 MHEV Titanium (6deg C, wet)**

Standing quarter mile 17.8sec at 81mph, standing km 32.3sec at 100.6mph, 30-70mph 9.6sec, 30-70mph in fourth 13.5sec

**Renault Captur 1.3 TCe 130 S Edition EDC (8deg C, dry)**

Standing quarter mile 17.4sec at 83.1mph, standing km 31.6sec at 103.5mph, 30-70mph 9.2sec, 30-70mph in fourth 11.3sec

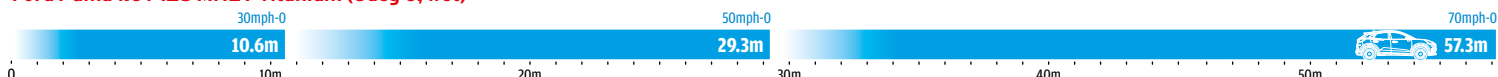
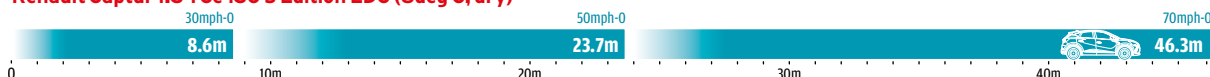
**BRAKING 60-0mph: 2.61sec****Ford Puma 1.0T 125 MHEV Titanium (6deg C, wet)****Renault Captur 1.3 TCe 130 S Edition EDC (8deg C, dry)**

FORD PUMA 1.0T 125 MHEV TITANIUM

On-the-road price	£20,845
Price as tested	£23,405
Value after 3yrs/36k miles	£11,225
Contract hire pcm	£231.07
Cost per mile	39 pence
Insurance	17E/£545

TYPICAL PCP QUOTE

Three years/36,000 miles £296.57
After a £2085 deposit, you'll be able to have a Puma for £296.57 per month over the course of 36 months. Annual mileage stands at 12,000. An optional final payment of £8857 will apply if you want to purchase the car outright.

EQUIPMENT CHECKLIST

- 17in alloy wheels ■
- Projector headlights with LED DRLs ■
- Automatic headlights ■
- Ford Megabox extended boot space ■
- Heated, power folding door mirrors ■
- Cruise control ■
- Lane keep assist, departure warning ■
- Wireless charging pad ■
- Rain-sensing wipers ■
- Rear parking sensors ■
- Quickclear heated windscreen ■
- Selectable drive modes ■
- Electronic air temperature control ■
- Pre-Collision Assist with Autonomous Emergency Braking ■
- 8.0in Sync3 touchscreen infotainment including sat-nav, Apple CarPlay, Android Auto, DAB, Bluetooth, aux, USB, MP3 ■
- Driver Assistance pack** ■ **£900**
- Grey Matter paint** ■ **£750**
- Comfort pack** ■ **£300**
- Rear privacy glass** ■ **£250**
- Options in bold fitted to test car
- = Standard na = not available

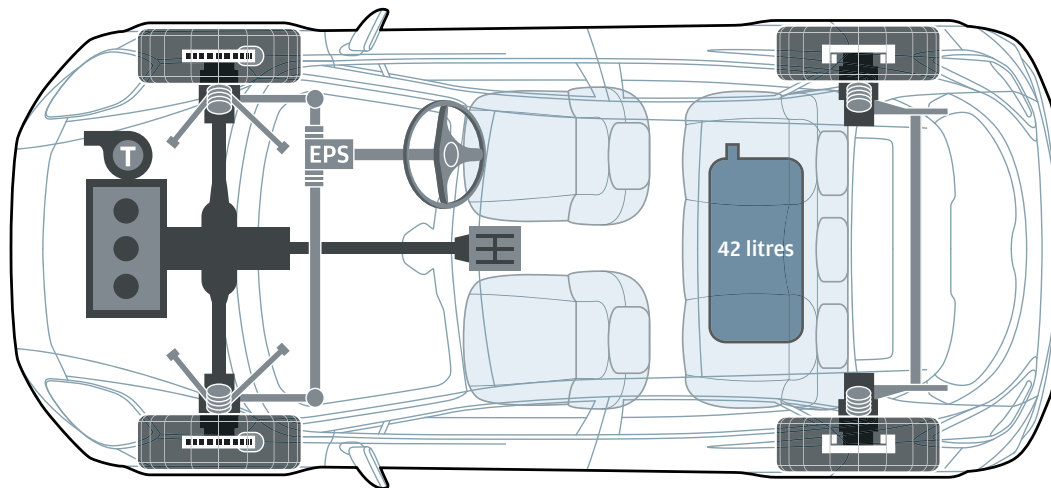

TECHNICAL LAYOUT

Puma sits atop Ford's Global-B small car platform. Suspension is typical compact crossover fare, consisting of MacPherson struts up front and a torsion beam at the rear. A 1.0-litre three-pot is mounted transversely at its nose, driving the front wheels through a six-speed manual gearbox. Brakes are via discs at the front and drums at the rear. We weighed the Puma at 1260kg, split 60:40 front to rear.

ENGINE

Installation	Front, transverse, front-wheel drive
Type	3 cyls in line, 999cc, turbocharged, petrol
Made of	Cast iron block, aluminium head
Bore/stroke	71.9mm/82.0mm
Compression ratio	10.5:1
Valve gear	4 per cyl
Power	123bhp at 6000rpm
Torque	155lb ft at 1750rpm (e-assist)
Redline	6500rpm
Power to weight	102bhp per tonne
Torque to weight	129lb ft per tonne
Specific output	123bhp per litre



ECONOMY

TEST MPG	Track	27.3mpg
	Touring	50.0mpg
	Average	39.0mpg
CLAIMED	Low	43.5mpg
	Mid	55.4mpg
	High	61.4mpg
	Extra high	47.1mpg
	Combined	51.4mpg
	Tank size	42 litres
	Test range	360 miles

EMISSIONS & TAX

CO₂ emissions	96g/km (NEDC eq)
Tax at 20/40% pcm	£80/£160

CHASSIS & BODY

Construction	Steel monocoque
Weight/as tested	1205kg/1260kg
Drag coefficient	0.32
Wheels	7.0Jx17in
Tyres	215/55 R17 98W, Goodyear Efficient Grip Performance
Spare	Repair kit

TRANSMISSION

Type	6-spd manual
Ratios/rev per 1000rpm	1st 3.42/5.3 2nd 1.96/9.2 3rd 1.28/14.1 4th 0.94/19.1 5th 0.76/23.7 6th 0.63/28.6
Final drive ratio	4.35:1

SUSPENSION

Front MacPherson struts, coil springs, anti-roll bar
Rear Torsion beam, coil springs, anti-roll bar

BRAKES

Front	278mm discs
Rear	228mm drums
Anti-lock	Standard, with brake assist
Handbrake type	Lever
Handbrake location	Centre console

STEERING

Type	Electromechanical, rack and pinion
Turns lock to lock	2.8
Turning circle	10.0m

SAFETY

ESC, ABS, TMPS, PCA, AEB, pedestrian detection
Euro NCAP crash rating 5 stars
Adult occupant 94% **Child occupant** 84%
Pedestrian protection 77% **Safety assist** 74%

CABIN NOISE

Idle 42dB **Max rpm in 3rd gear** 73dB
30mph 61dB **50mph** 64dB **70mph** 67dB

ACCELERATION

MPH	TIME (sec)
0-30	3.6
0-40	5.3
0-50	7.2
0-60	10.0
0-70	13.2
0-80	17.4
0-90	23.2
0-100	31.7
0-110	-
0-120	-
0-130	-
0-140	-
0-150	-
0-160	-

ACCELERATION IN GEAR

mph	2nd	3rd	4th	5th	6th
20-40	3.1	4.6	6.7	-	-
30-50	3.6	4.6	6.2	8.2	11.3
40-60	-	5.1	6.5	8.4	11.9
50-70	-	5.9	7.3	10.0	16.0
60-80	-	7.1	9.2	13.4	20.6
70-90	-	-	11.1	17.3	-
80-100	-	-	13.8	-	-
90-110	-	-	-	-	-
100-120	-	-	-	-	-
120-140	-	-	-	-	-
140-160	-	-	-	-	-
160-180	-	-	-	-	-
180-200	-	-	-	-	-

MAX SPEEDS IN GEAR

34mph 6500rpm	91mph 6500rpm	119mph 5028rpm
1	3	5
2	4	6
60mph 6500rpm	119mph 6218rpm	119mph* 4168rpm
		*claimed

RPM in 6th at 70/80mph = 2451/2802

RESIDUALS

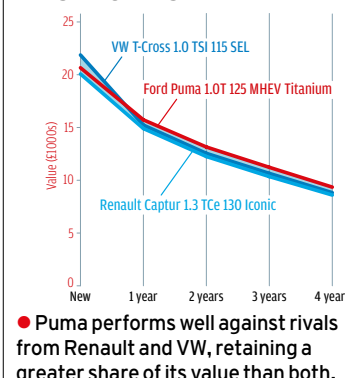

THE SMALL PRINT Power-to-weight and torque-to-weight figures are calculated using manufacturer's claimed kerb weight. © 2020, Haymarket Media Group Ltd. Test results may not be reproduced without editor's written permission. For information on the Puma, contact Ford Customer Relationship Centre, Royal Oak Way South, Daventry, Northamptonshire, NN11 8NT (020 3564 4444, ford.co.uk). Cost-per-mile figures calculated over three years/36,000 miles, including depreciation and maintenance but not insurance; Lex Autolease (0800 389 3690). Insurance quote covers 35-year-old professional male with clean licence and full no-claims bonus living in Swindon; quote from Liverpool Victoria (0800 066 5161, lv.com). Contract hire figure based on a three-year lease/36,000-mile contract including maintenance; Wessex Fleet Solutions (01722 322888).

AUTOCAR ROAD TEST

Read all of our road tests autocarmalaysia.com

Testers' notes

SIMON DAVIS
While I'm still not entirely sold on the B-SUV as a concept, the Puma is undoubtedly the car the segment has been crying out for. Always great when you're genuinely pleasantly surprised by something.



MATT SAUNDERS
The contrast between the Puma and its B-SUV range-mate, the EcoSport, is so stark that you wonder if the latter wasn't actually the canniest bit of strategic product planning in recent industry history. A great car is made to seem even better, after all, by immediate comparison to a really awful one.



VERDICT
★★★★★

The driver's car this class has been crying out for, and more besides

Ford has landed what might be its biggest achievement in more than a decade with the new Puma. It has succeeded where other manufacturers have failed and has furnished the still-growing and all-important compact crossover market with a car that represents the company's long-standing core strengths brilliantly.

The Puma has really distinguishing design appeal and, for its handling deportment and its universal driver appeal, it rises above the standards of its peers even more clearly. As our test car also proved, you don't need the most powerful engine or sportiest trim to experience the car at its dynamic best; and you needn't accept compromises to practicality, refinement or ride comfort in exchange for any of its dynamic strengths.

Much as the completeness of its dynamic performance impresses, the Puma is just a little bit plain and ordinary in terms of on-board technology and perceived quality and it doesn't excel for fuel economy quite as you might imagine a modern hybrid might; so it misses a five-star score. But this is unquestionably our new number one crossover – and we've been waiting a long time for it.

Spec advice

Unless you're absolutely sold on the sportier looks and set-up of the higher trims, stick with Titanium spec. The £300 Comfort pack is a worthy option, as is the £900 Driver Assistance pack.

Jobs for the facelift

- Keep refining the control software for that hybrid system. The real minutiae of the pedal feel could still be improved.
- Drive up the quality of the background cabin materials to banish any hint of cheapness.
- Make the electronic stability control properly switchable.

ROAD TEST RIVALS



FORD PUMA 1.0T 125 MHEV TITANIUM
Sharp, wieldy handling, a practical interior and impressive ride refinement and performance. A big win for Ford.
★★★★★



VOLKSWAGEN T-CROSS 1.0 TSI 115 SEL
Well-rounded T-Cross isn't as sharp to drive as its rivals, but it is comfortably the most polished and easy to live with.
★★★★★



MAZDA CX-30 2.0 SKYACTIV-G 122 SE-L
Slightly bigger than the Ford, but similarly fleet-footed. Naturally aspirated engine is a bit weedy and ride can lack sophistication.
★★★★☆



SEAT ARONA 1.0 TSI 115 FR
Handsome, spacious, fun to drive and impressively affordable. A consummate all-rounder, if not quite as refined as its VW sibling.
★★★★☆

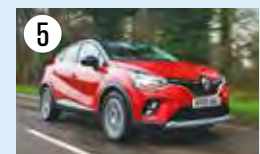

RENAULT CAPTUR 1.3 TCE 130 S EDITION EDC
Sturdy, agile handling undermined somewhat by an at times brittle ride. Practical enough, though.
★★★★☆

Price	£20,845	£22,370	£22,895	£21,245	£20,295
Power, torque	123bhp, 155lb ft	114bhp, 148lb ft	121bhp, 157lb ft	114bhp, 148lb ft	128bhp, 177lb ft
0-62mph, top speed	9.8sec, 119mph	10.2sec, 120mph	10.6sec, 116mph	9.8sec, 118mph	10.6sec, 121mph
CO ₂ , economy	96g/km, 51.4mpg	113g/km, 46.8mpg	116g/km, 45.6mpg	110g/km, 43.5-47.9mpg	127g/km, 44.1mpg



IN WITH A SHOUT



The Jaguar F-Type may be getting on a bit, but it isn't going quietly. Can the latest, raucous R-badged incarnation hold a candle to Porsche's finely honed 911 Carrera 4S? **Matt Saunders** decides

PHOTOGRAPHY LUC LACEY

The Jaguar F-Type is back, with a fresh look and an assortment of new bells and whistles. They have, thankfully, resisted the urge to treat it to a new pair of beige slacks and a matching M&S cardigan, although that must have been tough. Alright, there's a bit more to the update than the above would imply (a modest engine power hike, a new engine derivative, some new suspension componentry and some digital instruments) but perhaps not as much as you might imagine would be necessary to keep a current sports car up to date in what is now – wait for it – its eighth year in production.

Is it entirely fair, then, you may wonder, to pitch the 'new', range-topping R version of this car into a head-to-head contest with the only-a-year-old 992-generation Porsche 911? Knowing what we already do about the latter – it's a group test winner already and was highly commended at Britain's Best Driver's Car shootout, don't forget – is that a contest the plucky Brit can possibly win?

Well, it's certainly a curious notional position for the fresh meat in one of these twin tests to occupy. Usually it's the most recently launched car that comes in with all the advantages, yet the Jaguar holds nothing over the lighter, faster and fundamentally newer Porsche that might give it an on-paper head start here – save, perhaps, the peak outputs of its supercharged 5.0-litre V8 engine.

But here is the truth you'll discover having driven these cars extensively and one after another: there are some things the new Jaguar F-Type R P575 AWD does every bit as well as a Porsche 911 Carrera 4S; there are a handful of things it does even better, actually. I must add for the sake of balance that there are also plenty of ways in which the German is quite plainly the Brummie's superior. And yet what you're about to read is a contest, trust me, not a pushover. The Jaguar, for all of the long-toothedness that the new styling and interior smartening seek to disguise, has its shout, and for some – maybe even for you – it will be the better car.

Did someone say 'shout'? My ears are still ringing, as it happens. The first thing I'm happy to confirm is that a range-topping Jaguar sports car with a Welsh-made supercharged V8 engine could out-shout just about any 911 road car it happened to be within a few hundred metres of.

There's mention of a 'quiet' mode in the car's press material, and naturally you assume – having heard the thing snarling through the middle of its rev range at full load like a band of bloodthirsty sousaphone players – it might be a misprint. In fact, it's a convenience feature that Jaguar would seem to have appropriated from close



rival Aston Martin: it allows you to start the car's engine discreetly on an early weekday morning so as not to upset the neighbours. Or the neighbour's neighbours. Or, for that matter, the night-shift staff at your local early-warning earthquake monitoring station.

In actuality, 'quiet start mode' is nothing more or less than the car's normal running setting; if you want noisy, you simply select Dynamic mode or the active exhaust's loud setting before turning over the engine (and then, presumably, you just move house). So it's not even a new button in an otherwise pretty familiar cabin that, but for some new trim materials (nice matt black door handles, by the way, folks) and the new digital instruments and infotainment system, could perhaps have done with more of a material lift.

The Porsche would have been my bet to get its nose in front when these cars were compared as stationary, daily use ownership prospects, no question. But for every blow the 911 lands, the F-Type lands one right back.

You're a little more squeezed into the Jaguar, it's true, but the seat it offers to your backside is softer and more comfortable than the 911's and barely any less adjustable or supportive. It also needs slightly less of a bend-and-stoop manoeuvre to slide into.

The Porsche offers more room for your extremities, along with those occasional back seats for your clobber, better visibility, a better driving position, significantly more sophisticated and usable on-board display and infotainment technology, and significantly better perceived quality. The neat look and substantial feel of its switchgear is a cut above and then some.

But the Jaguar conjures a warmer and more inviting feel: its palette of decorative materials is wider and more imaginative, its ambience richer and a shade more luxurious. Sure, it doesn't have back seats, but that sizeable boot is usefully bigger than any one storage space the 911 has.

And so if you had to pick one of these cars just to use as personal transport for an undefined →



“ There are some things the F-Type does as well as the 911; there are a handful it does better ”

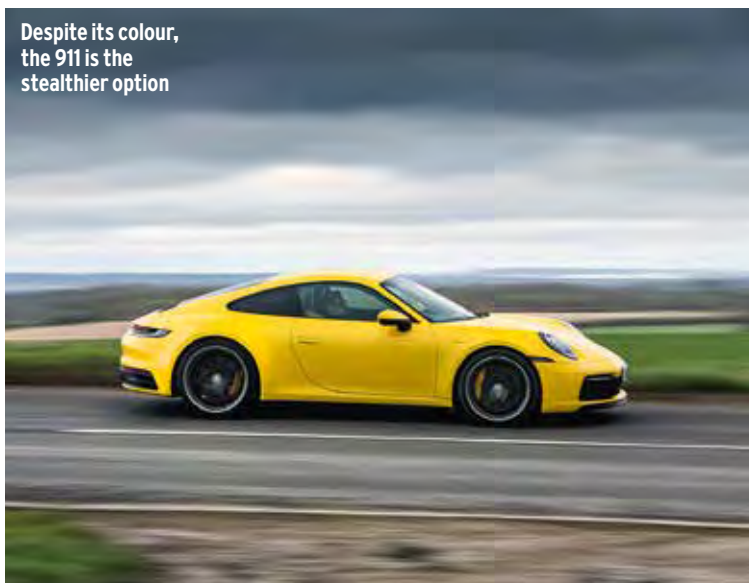

Despite its colour, the 911 is the stealthier option



The F-Type R has a more settled ride



F-Type R at least has a usable boot



The 911's 20/21in wheels induce roar



Rear-engined 911 wants for load space



Jaguar actually added four-wheel drive to the R model earlier in the F-Type's life. The new car's extra power and torque make it the equal of the old SVR, although it is a little heavier.

You'll hear the Jaguar coming before you see it, as will everyone else



F-Type R gets a forceful 567bhp V8



911's responsive flat six has 444bhp



“
The Jaguar has too much power, too much weight and too much traction
”

← period of time, without a thought given to how much fun you might have in the process, I'm not totally convinced the Porsche would be the automatic choice. It has been executed with typical German precision and attention to detail, so the sat-nav is easier to programme and more reliable and it's easier to find the instrumentation mode that suits you best. By contrast, on one occasion when I pressed the button that I imagined would activate the voice recognition on the Jaguar's navigation system, all it did was mute the radio. So much for the British technological avant-garde.

On paper, the F-Type's torque-to-weight ratio looks very healthy, but it's the 911 that feels more tractable from fairly low revs, and it picks up more effortlessly.

But it's the Jaguar that does better for refinement and rolling comfort – and that means it would double up better as the grand touring part-timer. The Porsche's ride is noisier than the Jaguar's (on those optional mixed-sized RS Spyder Design 20/21in alloys and optional PASM lowered sports suspension, admittedly), and it lacks a little bit of the supple dexterity that typically characterises mid-range 911 variants. It reads just that little bit too much information from the road surface for ideal daily driven comfort, you'd say. The Jaguar, by contrast, can get feisty and reactive over an uneven surface, but it's quieter and better isolated on most others. The Porsche, being a rear-engined 911, is also less naturally stable at high speeds than the Jaguar and more easily disturbed by camber and crosswind, both of which have a part to play in defining how wearing it might be to use.

Not that a 911 is ever likely to wander quite as far off course – as some might say the narrative thread of this test already has. Hands up, you got me: not many people buy sports cars for their refinement levels or the rich luxury feel of their interiors. It's just possible that I've been finding reasons, thus

far, to award extra credit to a charismatic and likeable British alternative that – you've guessed it – can't quite match even a pretty sub-optimally equipped 911 for driver appeal. That's a shame and not exactly a shock, but if you don't do these things properly, you never really know.

There's just a bit too much of the F-Type R to allow it to hit the same dynamic heights as the Porsche or to impress its driver quite as clearly at both low speeds and high. It has too much power, too much weight and, at least for this tester, at times a shade too much mechanical grip, traction and lateral stiffness necessary to harness the →



F-Type has better GT credentials despite its power surplus

← aforementioned and to move it all around to be good for the car's wider sporting appeal. It might have newly configured suspension and better rear axle location, but the F-Type R remains the burly, surly hotrod that you guide with plenty of concentration and a slightly wary hand.

By way of contrast, the 911 is at once more communicative and can be coaxed more precisely and instinctively than the F-Type. It's easier to drive quickly and feels more special when driven slowly – although, it must be said, the enticing rumble of the Jaguar's engine is pretty special also. And what an engine. If only it came with

drivability the equal of its audible drama. Some Porsche flat sixes might be able to compete with a great V8 like the F-Type's for audible character (and the one in the car in our little twin test below gets pretty close, by the way), but a modern twin-turbocharged one doesn't. The Bridgend 5.0-litre is never better than when gargling majestically from 3500rpm to 5000rpm at full throttle, and then crackling after a lift as if the music has just stopped at a fireworks display.

But before you've learned to keep the Jaguar's gearbox in manual mode in order to prevent it from needing to shuffle ratios before it can →



718 vs 911: SHOULD YOU GO LITTLE OR GO LARGE?

Critics of the latest Porsche 911 claim that it has become too wide, too soft, too heavy and too complex to work quite as perfectly as the any-occasion sports car its best predecessors have been. At times, I've agreed with some of what I've read on that score – albeit only because I know how great some of those predecessors were. So, is the 911's status as the defining Porsche driver's car ripe for inheritance by the smaller 718, with its returning six-cylinder engines?

I thought so. But then the Cayman GT4 we had at Best Driver's Car 2019 failed to entertain at Anglesey Circuit nearly as well as the 992-generation 911 Carrera S. Matter settled, then? Not for me, I'm afraid. It's still lingering like a bad smell.

Leaving track driving out of the equation, if only for the sake of argument, can a six-cylinder 718 Spyder beat a 911 Carrera 4S now for mixed on-road appeal? It's a less weighty question than the one I had intended to answer, but right now I'd say the best 718 is the better driver's car, defined strictly in those on-road terms.

There are all the obvious reasons: at the moment, you can't buy a 911 with a manual gearbox and there is as yet no extra-special, normally aspirated flat six that has been signed off for it by the GT division. The 718 Spyder is all the reminder you need of what the 911 is missing in both respects: its engine is fantastic (although it has curiously long gear ratios to wade through), it sounds incredible as it passes 5500rpm and it has a crispness and linearity to its delivery that turbochargers just can't replicate.

The 718's ride and handling don't quite match those of the 911 for complexity and character. Driving them back to back is a bit like comparing Heath Ledger's Joker with that of Joaquin Phoenix: the 911, like Phoenix, simply has more going on. But it's a close enough thing to give the smaller car the nod, albeit in an incomplete and unfair exercise. Right now it's the 718 I'd have. Which, I'm afraid, settles precisely nothing.

Six-cylinder power has returned to the 718 line-up



718's naturally aspirated motor is crisp and linear

“
The 718 is a reminder of what the 911 is missing
”



718 has more appeal as a driver's car – on the road, at least

← respond meaningfully to any lug of power, you'll find it's the Porsche's combination of twin-turbo flat six and eight-speed dual-clutch automatic transmission that's more likely to be in the right gear and ready to go, whenever you might need it to be. The Jaguar's engine is a wonderful treat when at its very best, but it's less consistently brilliant than that of the Porsche.

Precisely the same observation could be made about the respective chassis of these cars. The Jaguar gets into a lovely fluent stride when conditions suit it, when the bends are faster and smoother and there's a bit of room to give the engine its head and feel the rear axle gently squirm with the workload. It begins to sit heavily on its dampers when the surface gets tougher, though, and particularly so in its Dynamic mode.

Meanwhile, the sense of slightly muted elasticity and tactile compliance evident in the steering, which doesn't bother you so much when you're arcing more gently around curves, increasingly becomes an obstacle when you're continually turning this way and that.

The Porsche steers superbly; you feel as if you can adjust the car's course by the millimetre and as if you know the instant the front sidewalls load up every time you turn the rim. It doesn't do fast and fluent quite like the Jaguar but, instead, from both powertrain and chassis, it produces this super-responsive yet entirely progressive sense of poise. It's fit for any road or track and would make you guess its weight advantage over its rival was greater than it really is.

And it always involves. This may be a well-worn road test cliché, but while the Jaguar feels at times like it's launching you into conflict with the surface underneath you and the physics acting upon it, the Porsche engages you in a fascinating, instructive conversation with both. Want to go faster? Here's how, it seems to say. Fancy a different line and way around that bend of yours? Take your pick.

It must be a fearsomely disheartening task for any car maker to beat a driver's car as dynamically versatile and accomplished as the current 911. For all of its little victories, the F-Type R fell some way short in the final reckoning. There was one car we had along for the ride that didn't (see p53) – not that Weissach need worry because, as it happened, it took a Porsche to beat a Porsche.

And Weissach wouldn't for one moment worry anyway, of course, because as much as the F-Type feels like its race is pretty much run, we all know that the 992 is only just getting started. It's Turbo soon and GT3 not so long after that, so they say. Yes very much please, would be my reply. 🏁



F-Type R cossets nicely but its in-car tech lets it down



911 has a better driving position and a higher-quality feel

PREVIOUSLY OWNED POWERHOUSES FOR THE PRICE OF A NEW 911 OR F-TYPE



FERRARI FF

The FF made the notion of a four-seat, four-wheel-drive Ferrari acceptable and paved the way for the mightily impressive GTC4 Lusso. Wonderful 651bhp V12, 208mph and 0-60mph in 3.7sec mean it's no slouch. Also has a hatchback and folding rear seats, so a must for Courchevel. Buy from around £100k.



LAMBORGHINI GALLARDO LP560-4

True, the LP560-4 will feel antiquated next to an ultra-modern 911, but the Gallardo just has that added sense of drama that the evergreen but continually updated Porsche simply can't muster. Despite a new price of roughly £200k, you can now pick up this V10-powered Italian monster for just £90k.



HONDA NSX

Soon even the supercar won't be immune from electrification. The clever people at Honda know this, which is why the current NSX is a hybrid marvel with three electric motors assisting the twin-turbo 3.5-litre V6, giving an output of 573bhp. Expect to pay £90k for a 2017 example with minimal mileage.

	PORSCHE 911 CARRERA 4S COUPE PDK	JAGUAR F-TYPE R P575 AWD COUPE
Rating	★★★★☆	★★★★☆
Price	£98,418	£97,280
Engine	6 cyls horizontally opposed, 2981cc, twin-turbo, petrol	V8, 5000cc, supercharged, petrol
Power	444bhp at 6500rpm	567bhp at 6500rpm
Torque	391lb ft at 2300-5000rpm	516lb ft at 3500-5000rpm
Gearbox	8-spd dual-clutch automatic	8-spd automatic
Kerb weight	1565kg	1743kg
0-62mph	3.6sec	3.7sec
Top speed	190mph	186mph
Economy	27.2mpg	26.4mpg
CO ₂ , tax band	237g/km, 37%	243g/km, 37%

2nd

Loads of hotrod charm and brutish drama, with impressive pseudo-GT usability. Not as precise or involving as the Porsche, though, and may not be the best F-Type either.



1st

Not the very best example of a 911 that, by its own standards, still has room for improvement as a driver's car. Still good enough to keep the Jaguar at arm's length.





SMOOTH OPERATORS

Slick, battery-powered superminis make perfect sense for the urban cut and thrust of daily use, and soon we'll be spoiled for choice.

James Disdale pits three of the current contenders against each other

PHOTOGRAPHY JOHN BRADSHAW



Electric cars have come and gone over the years, gaining and waning in popularity as eco-friendly fashions have flared and faded, but this time they're here to stay. Of course, the government's proposal to ban the sale of new internal combustion-engined cars by 2032 plays its part in their assured future, but it's the recent rash of battery-powered superminis that really points the way to their permanence.

Small cars are big business but the margins are slim, so to invest hefty sums packaging them with expensive electrical internals is as strong an EV endorsement as you'll get from the automotive industry. Almost all of the major players are in the process of launching a pure-electric supermini or city car, while many have already arrived.

Perhaps the most eagerly anticipated is the Mini Electric, which has been on the cards since the Mini E began field trials over a decade ago. While rivals have taken a cooking approach to their EV babies, Mini has spiced up its offering with a 181bhp motor (shared with the BMW i3s) and Cooper S badging, making this a hot hatch without the environmental hitch.

The 134bhp Peugeot e-208 (you can leave your Yorkshire-tinged French hatchback jokes at the door) trails the Mini on performance but promises greater practicality, both in terms of the space available in its five-door shell and its promised 217-mile range. The Mini can muster just 144 miles, although the claims for all three cars here should be taken with a pinch of salt, as we shall see.

Both have to give best to the 238-mile WLTP figure for the Renault Zoe, which appears here freshly facelifted and complete with a more powerful motor – now 132bhp – and

greater stamina from larger 52kWh lithium ion cells. Unlike its rivals here that have been developed to be propelled by fossil fuels as well as electricity, the Renault is exclusively an EV. It's also Europe's best-selling small electric car by miles.

Visual updates to the Zoe have been minor, its LED-haloed headlights being the most obvious change to the tall and narrow machine. It's distinctive but not as handsome as the e-208, which is one of the French firm's most successful small car designs since (whisper it) the 205. Only the clunky wheel-arch extensions jar visually – although at least they are functional, covering



Peugeot gets neat 3D instruments



Floating dials add to Mini's classy feel



Updated Zoe has better TFT screens



In Sport mode the e-208 is impressively quick off the line

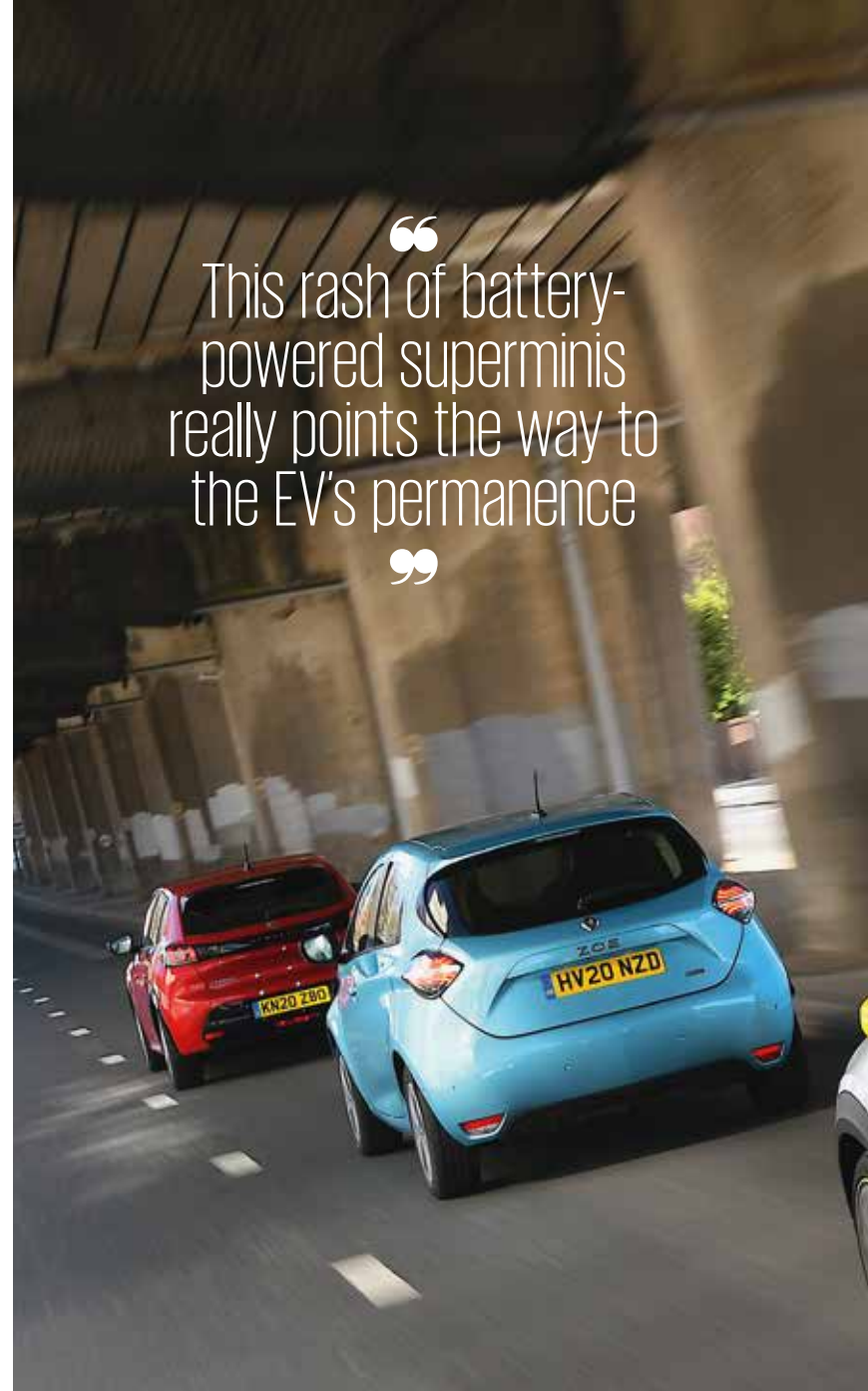

“ This rash of battery-powered superminis really points the way to the EV's permanence ”

the wider rear track necessary to accommodate its lithium ion battery.

Despite its basic shape being the most familiar, it's the Mini that attracts the most attention, with alloys that appear to have been designed during a Minecrafting session and lemon yellow trim inserts at least helping to turn heads.

Inside, the Mini has its rivals licked for quality and ambience, the standard car's impeccable fit and finish enhanced by the neat 'floating' instrument cluster sitting ahead of the driver. There's precious little space, though. Driver and passenger are comfortably catered for but those



SUB-£30K USED ALTERNATIVES



2019 HYUNDAI KONA ELECTRIC

Our test cars' budget could also buy you a barely used Hyundai Kona Electric. A whopping 64kWh battery gives the Kona up to 279 miles between plug-ins, which is far more than any of the others here. It's also good to drive, with punchy performance and a spot-on driving position, and decently equipped.



2014 TESLA MODEL S

It will be getting on a bit and have around 60,000 miles on the clock, but many will see that as a small price to pay for putting an on-trend Tesla on their driveway. It's only the 60kWh version but it claims a 208-mile range. Er, reliability might be an issue, though...



2019 BMW i3 120AH

For around £26,000, a used BMW i3 makes a good case for itself against the all-new Mini Electric. Examples from 2019 got an enlarged 42.2kWh battery pack, meaning it has similar electric range, plus there are back doors, so it's slightly more practical, and it can be rapid-charged as often as you like.

Energy-efficient LED headlights feature on all Mini Electrics and Zoes but are only standard on e-208 GT Line models and above - other versions get halogens.

in the back are cramped due to a rear bench raised to house the battery cells beneath. Access through the gap between the front seats and B-pillar is tight, and the 211-litre boot is no more than vestigial, particularly when full of charging cable.

The Renault's 338-litre boot is the biggest here, 27 litres up on the e-208, while occupants in the rear get more leg room than in the Mini. What they don't benefit from is head room, again due to a high-set rear bench forced by the battery under the floor. This extends to the front seats, meaning you're sitting on rather than in the Zoe. On the flipside,

the elevated view makes the Renault the most assured choice in the urban cut and thrust. Quality has improved over the previous versions, but there are still lots of hard and scratchy plastics alongside the new recycled fabrics and improved TFT screens.

Most welcoming is the Peugeot, its body packing the most space for people front and rear (it's easily the most family-friendly), while the bold dash architecture looks great. The 3D instrument cluster is a particular treat, provided you can see it over →



Peugeot's low-slung wheel obscures dials for some drivers

“
The Mini matches
the Peugeot’s hushed
approach yet lacks
its suppleness
”



← the small-diameter steering wheel (some of our testers couldn't). There are still some below-par plastics to be found, but overall the e-208's cabin feels classy and sophisticated.

It's an impression that's reinforced on the move, at which point the Peugeot makes the most of the unobtrusive benefits of electric power to deliver a smooth and refined driving experience. Our test route took in towns, motorways and some wiggly secondaries, and over all of them the e-208 is calmer than the competition. Its relatively soft suspension smothers bumps, and it's quiet, with even big impacts

issuing little more than a muffled thud from the springs and dampers.

Neither rival can get close to the e-208 in this regard. The Mini matches the Peugeot's hushed approach yet lacks its suppleness, while its extra firmness causes the car to follow rather than swallow imperfections.

The Zoe isn't as stiff-legged as the Mini but feels more brittle, with broken surfaces sending shudders through the structure. It's also noisier, the suspension clonking and crashing in protest over surfaces the



You sit high in the Zoe owing to its underfloor battery

other two keep to themselves. It also develops more wind and road noise than the other two, making it the least suited to longer-haul trips.

It's not the only noise issuing from the Renault, which at low speeds emits a strange Dan Dare-like sci-fi whirring intended to keep

pedestrians on their toes. Off the line, the Zoe's more powerful motor delivers a useful extra turn of speed, and like all electric cars there's instant urge and, up to around 50mph, the Renault feels warm-hatch quick.

Its regenerative braking is the weakest here, however, as even in B mode there's not as much retardation as in the e-208 and Mini, which can both be driven effectively as one-pedal cars in day-to-day dicing. The British-built machine's dash-mounted toggle for accessing the increased brake-energy

PLUG AND PLAY

The Mini can handle both AC and rapid 50kW DC charging as standard. Use a three-pin domestic socket and you're looking at a 12-hour charge time, which means a wallbox is a must-have. BP Chargemaster is Mini's preferred supplier and for £549 will install a unit that will slash electrical refills to just over three hours. Use one of the DC units and you can achieve an 80% charge in a smidge over half an hour.

Bigger batteries in the Peugeot and Renault mean longer charging times - the Zoe needs nearly 40 hours from a three-pin plug. You'll

need to pay an extra £1000 for the DC 50kW rapid-charging option on the Renault, but on the flipside the car comes with a 7kW installed wallbox included in the price. The e-208 is also currently available with a free wallbox installation, plus for £300 you can add the CCS DC charger that features a best-in-class 100kW charging capability, meaning 80% capacity replenished in half an hour.

Naturally all three feature sat-nav that can guide you to a public charging point - although they can't tell you whether it's actually going to be working when you get there...



The e-208 is available with free wallbox; DC rapid-charging is a £1000 option on the Zoe



powerful Mini for zest, though. The Cooper S responds to the throttle with an elastic energy that tricks you into thinking the car is lighter than it actually is. Again the linear delivery plays its part here, as does that muscular 199lb ft and lowest-on-test weight. Engaging Sport adds greater sharpness to the throttle, while in

all modes the Mini offers greater thrust at higher speeds, continuing to accelerate with reasonable vigour above 60mph - although from here on in it would be

shown a dirty pair of tailpipes by the internally combusted model.

The Mini continues to play the entertainer as the roads turn twisty, the Electric version serving up a puppyish up-and-at-'em agility. Curiously, the steering feels lighter than the ICE car, but there's some feel and it's as quick as ever. The Mini dives for apexes with the zeal of a bloodhound on the scent, and there's lots of grip and tight body control, while killing the throttle mid-corner results in a strong tightening of line, enhancing the sense of agility.

The Zoe feels vertiginously high after the Mini, almost SUV-like →

Factor in the plug-in grant, as we have here, and entry-level prices are £26,900 for the Zoe, £25,700 for the e-208 and £24,900 for the Mini Electric.

retardation is more of a faff than the two French machines, which require little more than slotting the gearlever to B.

While it has more power than before, the 1502kg Zoe succumbs to the Peugeot for get-up-and-go. That said, the Peugeot doesn't feel as quick as the figures suggest, its impressive refinement sapping some of the speed sensations. Switching to Sport takes some resistance out of the throttle pedal for quicker response while raising the top speed to 93mph and rendering the e-208 a demon starter away from the lights.

Neither can match the far more



Renault's ride is noisy and can feel harsh; Peugeot is soft and quiet



Mini's cabin has by far the classiest feel, fit and finish



Mini's range is the poorest here, at barely 100 real-world miles

← from behind the wheel. And while the flat seats are fine at a cruise, they offer little support as cornering forces grow. The Zoe clings on harder than you'd think but lifeless steering means it's not exactly fun, although a lowish centre of gravity and decent body control allow you to scoot through bends with poise and pace.

You feel better located in the lower-slung Peugeot, which on initial acquaintance slices through corners with a familiar French fluidity. If anything the steering, heavier than the Mini's, is a little too sharp, but it's precise and there's decent front-end bite. Push harder and the composure cracks as the softer dampers fail to control bigger body movements and the e-208's nose ploughs wider, sooner. Lifting the throttle gets

things back on track, but neither French car is as adjustable and biddable as the fun-loving Mini. Where the Peugeot and Renault really score over the Cooper S is in their ability to travel further between charges.

Arguably range is even more important on small cars, which are likely to be town-bound where driveways are in short supply, meaning you'll have to fight it out with others for roadside chargers. Realistically you can knock about 40 miles off the WLTP figures for all of these machines. That drops the Mini's real-world figure to just north of 100 miles, which is poor

The Mini's neat new dial pack looks great, until it's hit by direct sunlight and you realise the main gauge isn't TFT but an analogue unit behind a heavily tinted screen.

1st

Smooth, spacious, comfortable and has a good range. Not the sharpest drive, but it's the most convincing small electric car yet.



Zoe's claimed range of 238 miles equates to 200 in daily use

compared with the easy 170 miles-plus achievable in the other two. The Mini's range lacks the resilience of the others, too. Its miles drop off as you crank up the air-con, switch on headlights or use that extra performance. The French pair are less affected, helping to instil a confidence that you can travel as far as the readout insists that you will. That said, none of our trio likes high cruising speeds, which see the miles tumble from the range faster than they roll under your wheels. So where does that leave us? Well, matters are complicated by the fact that these are three very different takes on the small EV, each trying to attract a slightly different type



3rd

Impressive range, decent space and great around town, but a relative lack of sophistication is harder to justify, particularly in pricey GT Line guise.

2nd

Mini is hard to beat for sheer brio, and its rabble-rousing entertainment value is largely undiminished. Best to drive by a mile but severely hobbled by limited range and practicality.

of buyer. Plus there's the thorny subject of price: even in their most basic guises these are expensive superminis, and that's taking into account the potential 'fuel' savings.

The Renault's range is truly impressive, plus it offers decent practicality. Yet it can't match the other two for quality, refinement or driver appeal. And it feels less expensively engineered than its pair of rivals, which would be fine if it didn't cost more than them to buy. Less expensive versions of the Zoe make more sense than this GT Line.

The Cooper S feels like nothing less than a premium product, and for driving fun it's head and shoulders above the rest, plus at £24,900 for the

entry-level model it's fractionally the most affordable. Yet it's hamstrung by that range and an interior that is a little too bijou for it to double up as the sort of occasional family transport supermini drivers typically demand – in terms of space it's more of a Volkswagen e-Up rival.

The Peugeot? Well, it's the most compelling package, striking a neat balance between the practicality and range of the Renault and the quality and refinement of the Mini. No, it's not the most thrilling to drive, but it features the most even spread of talents and demands far fewer compromises – and for a motoring public getting used to an inevitable EV future, that's a good thing. **A**

	PEUGEOT E-208 ALLURE PREMIUM	MINI ELECTRIC 2 COOPER S	RENAULT ZOE R135 ZE 50 GT LINE
RATING	★★★★☆	★★★★☆	★★★★☆
Price	£27,550 (after government grant)	£26,900 (after government grant)	£29,695 (after government grant)
Engine	Asynchronous electric motor	Hybrid synchronous electric motor	Permanent magnet synchronous electric motor
Power	134bhp	181bhp	132bhp
Torque	192-221lb ft	199lb ft	181lb ft
Gearbox	1-spd automatic	1-spd automatic	1-spd automatic
Kerb weight	1455kg	1326kg	1502kg
0-62mph	8.1sec	7.3sec	9.5sec
Top speed	93mph (Sport mode)	93mph	87mph
Battery	Lithium ion, 56kWh	Lithium ion, 32.6kWh	Lithium ion, 52kWh
Range	217 miles (WLTP combined)	144 miles (WLTP combined)	238 miles (WLTP combined)

BMW'S GLORIOUS

The BMW i8 was an inspired car ahead of its time, says Andrew Frankel, yet it ends its life without being replaced and will be classified as a failure. Why?

PHOTOGRAPHY MAX EDLESTON



FAILURE

I first drove a BMW i8 in 2014. And when I was done, seeking to compare it to anything else that might remotely be considered a rival, I sat down and wrote: "It is the odd one out only because it is so demonstrably far ahead of its time. Others will react and may well do an even better job than the far from flawless i8, but for now it has the field to itself and its every success will be deserved."

Well, I got that wrong. Others didn't react. It was then and remains today the only car of its kind. Truly, I don't think it occurred to me that it might fail, but fail it has: the fact that BMW has chosen not to replace it tells you that. As does losing half its value in its first year.

It takes a lot to make me sad at a car's passing: these things we think we love are, after all, mere objects at our disposal and in this business there's always some other interesting device to go and drive. But the i8, to me at least, is different. When I look back over all the long-term test cars I've run on this magazine, the McLaren 720S is obviously the one I miss most; but the i8 is next and not that far behind.

And I will miss it in two ways. Most simply, I'll miss what it does. The quick adrenaline shot just upon seeing it first thing in the morning, coupled with the knowledge that it will make special everything from a cross-continental adventure to a trip to the village shop because you've run out of milk. It still looks incredible, the novelty of its lines having never worn off.

It has never received fair credit for the way it drives, either. I'm not terribly bothered whether it oversteers or understeers on the limit, because it's not that kind of car. I care more about the fact that it's light and beautifully damped, with accurate and pleasingly geared steering. I like the powertrain, too: it sounds terrific, has no lag, and if anyone sneers about the sound being synthesised, I'd refer them to almost any decent car on sale. They all have a synthesised soundtrack to some →



BUYING AN i8

The i8 seems to be an exceptionally robust car, with occasional electronic niggles reported and not much else. Remember that depreciation is vertiginous in the first year but flattens out rapidly after that, so a nearly new example is an even better bet than usual. Consider whether the roadster is really worth the extra premium - I'd have the coupé all day long - and remember the car's flaws: minimal rear room, a tiny boot and doors that mean you always have to park in a space where no one can park too close next to you.



Frankel ran an i8 as a long-term test car and still misses it



Front wheels have their own electric motor



Its concept car looks always turn heads

← extent and in one way or another. I couldn't care less.

But the best thing about driving the i8 is how well matched the chassis is to the powertrain. It doesn't feel overpowered so you're not always on the brakes, spoiling the rhythm of the road. But nor does it feel like it could do with another 200bhp: its tyres are unfashionably slender, which is another reason it feels so good. It is baby bear's porridge: not too hot, not too cold, but just right.

But then there's this whole other way I'll miss it and, in fact, it is this rather more cerebral fondness that makes its departure something truly to regret. For with the i8, BMW revealed to the world a way forward at least for a certain kind of car. A way where your car still gets to go hard and sound good. A way where it's actually even better to drive because it is so damn light. A way where you can have your cake yet not get fat: a supercar that'll do 40mpg almost however you drive it.

And the world's response? "A BMW with a six-figure price and a three-cylinder engine from a Mini? You're kidding, right?" I admire BMW so much for having the courage to do

this car and that bravery deserved far better than this. I imagine the deep breaths taken around the boardroom table when the plan for this carbon-framed, aluminium-clad mid-engined masterpiece was signed off. It would have been hideously expensive to develop. They'd have known that, bar a convertible, there was no other car they'd be able to spin off the same platform. But they went ahead and did it anyway because it was the right car to do.

How were they to know that even by the 2020s, it would still be the wrong time to do it? Seems nuts, doesn't it? If I were to sit down and specify a less unsustainable kind of long-distance driver's car for our era, the only reason it wouldn't look like this is because I'm not smart enough to have thought of it. Yet BMW is getting rid of it while, at the same time, launching the M8 Competition, another similarly priced 2+2 coupé but one that weighs nearly two tonnes and is powered by a twin-turbo V8 engine.

But you can't blame BMW for the death of the i8. It had six years in the marketplace, so they gave it a decent run and it's not their fault



“ This is a way where you can have your cake yet not get fat: a supercar that'll do 40mpg however you drive it ”

WHAT ABOUT THE BMW i3?

Although the i8 is dead, happily BMW's 'i' adventure is not, but it seems that in future it will make only electric cars. First is the iX3, a Jaguar I-Pace and Audi E-tron rival coming this year, followed by an i4 next year, a car with Tesla's Model 3 in its sights.

For now, though, there is the trusty i3, launched before even the i8 and, for now at least and despite rumours of its imminent demise, apparently safe from the executioner's axe. For while it has never been a strong seller - anything but, in fact - sales have increased every single year since it went on sale in 2013, helped by changing attitudes, increasingly tax-friendly legislation, a couple of well-timed technology upgrades and closely controlled pricing.

And if it can be made to fit your life and you don't mind its highly alternative appearance, I think there remains a strong case for the i3. It's quick, it's fun and the interior still feels fresh and modern. Just remember that the range-extender model is no longer on sale so you'll have to put up with either a pure EV or find a REX on the used market.



the world proved resistant to the sea change it represented.

Even so, the real source of my sadness is that if BMW did replace it, I think its successor would stand a very good chance indeed. We live in a completely different world from that into which the i8 was born and, in one more generation's time, there will be no more two-tonne V8s. But there will be plenty of lightweight coupés with downsized hybrid powertrains because, with pure EVs, those are the only cars of this type that are going to survive the transition that is so swiftly coming our way.

Sure, some issues would have needed to have been addressed – more luggage room and a more special interior among them – but these are relative details. With a few years' development, a new i8 would have more power,

go further on electrons alone and use less fuel. It'd be even more relevant and then the world would finally wake up to the wonders within.

But now it won't get that chance. And what can we learn from this? That even producing one of the most advanced, interesting, attractive and effective cars of its time is no guarantee of success. The lesson of the i8 story is to try less hard, take fewer risks and do less well. And that's what is saddest of all. **A**



Its powertrain and chassis capabilities are a sweet match



Effortless progress is via a 1.5 petrol and two motors



HOW MUCH FOR AN i8 TODAY?



2015 i8 COUPE

£42,000 38,000 miles

You could probably haggle your way into an i8 for less than £40k now, which makes an older car sound incredibly cheap. But the real value is in newer models.



2019 i8 COUPE

£73,000 100 miles

There are loads of delivery-miles i8s out there for this kind of money: brand-new cars for £50,000 off list, despite their deserved reliability reputation.



2019 i8 ROADSTER

£76,000 5 miles

Proportionally, Roadsters lose even more money than coupés in their first year. The roof works well, but it spoils somewhat the lines of the car.

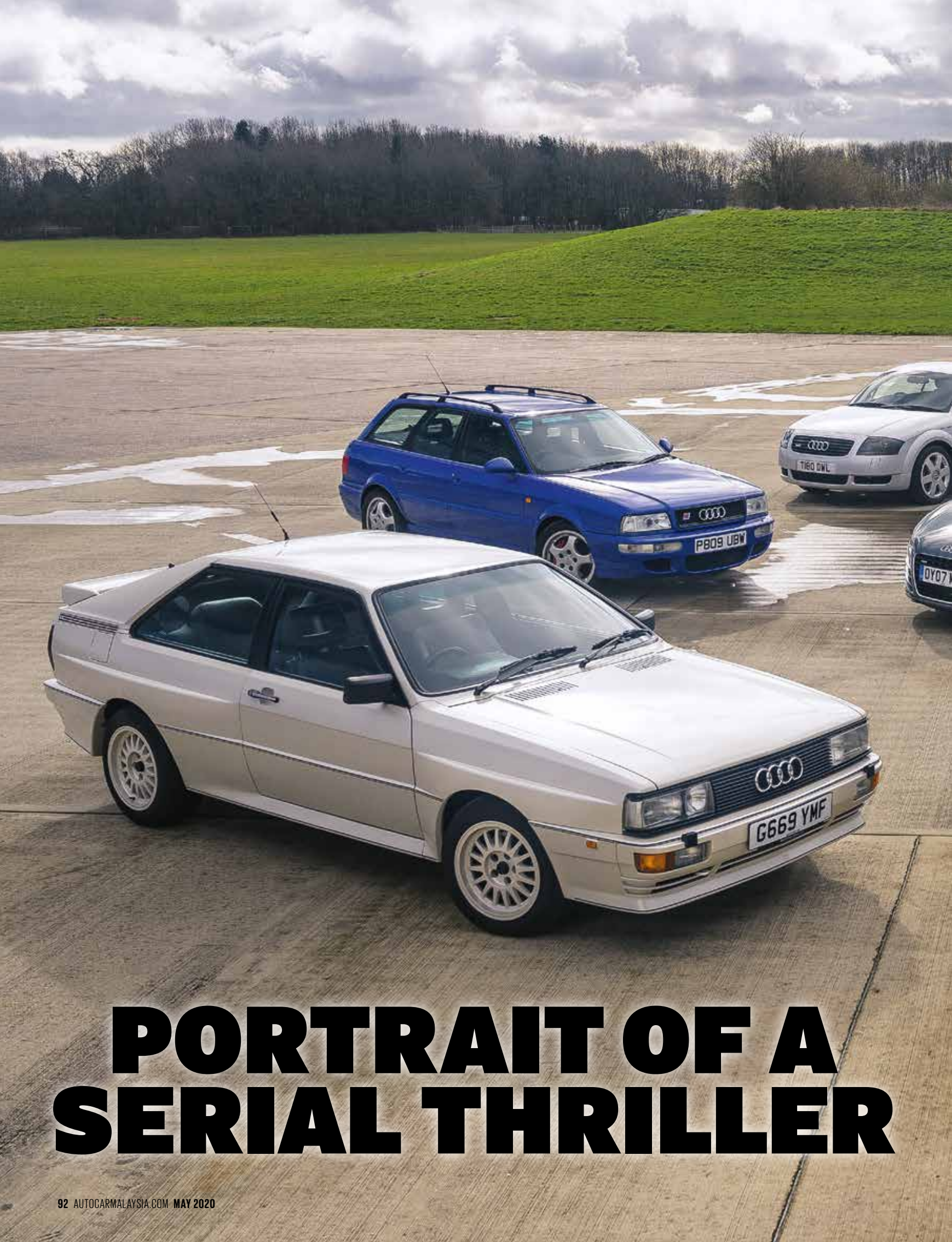

PORTRAIT OF A SERIAL THRILLER



It's now 40 years since Audi introduced the world to four-wheel-drive performance cars. **Andrew Frankel** climbs down the Quattro family tree

Almost all cars reckoned to be true pioneers turn out to be nothing of the sort. The Range Rover wasn't the first luxury off-roader, the Renault Espace wasn't the first MPV, the Volkswagen Golf GTI wasn't the first hot hatch and none of the Saab 99, Porsche 911 or BMW 2002 was the first turbocharged road car. And the Audi Quattro wasn't the first high-performance four-wheel-drive car.

That, of course, was the Jensen FF produced between 1968 and 1971. But like all of the aforementioned, the Quattro was the one that perfected and popularised its innovation. The problem with all previous four-wheel-drive cars, Jensen included, was that they needed to direct their power forwards through a heavy, clunky and bulky transfer box. This solution was impractical and expensive, which perhaps explains in part why just 320 FFs were built. What Audi did was find another way of doing the same thing.

It was Jörg Bensinger who realised that if you used a hollow output shaft from the gearbox, it could run into a centre differential mounted behind the gearbox, while a second shaft within the output shaft could then take the power forward to the front wheels. The need for a transfer box was bypassed and the first modern four-wheel drive system invented.

Bensinger and his team started work on this in the mid-1970s, but it wouldn't be until 1980 that the fruits of their labour could be seen in public, in the form of a boxy coupé called the Audi Quattro. Since then, Audi has never stopped using four-

wheel drive, and it has now been joined by most of the world's other major car manufacturers.

But for Audi, four-wheel drive proved far more than just a means of halving the tractive work load of each tyre. Quattro started life as a car, soon became an automotive legend and then turned into a sub-brand, to Audi what M is to BMW and AMG is to Mercedes-Benz.

But which Quattro machine is the greatest? With hundreds to choose from and only five examples allowed, it wasn't an easy process, especially as two places were already bagged by the original and the most recent.

Many will disagree with the chosen quintet, but I went for the final version of the original Quattro; the RS2 Avant as the first of the truly nuts estates for which Audi became so renowned; the original TT because it was a design revolution that did far more to democratise the sporting four-wheel-drive coupé than the Quattro; the Mk1 R8 because, well, it's an R8; and the latest RS6 Avant panzerwagen. I know: no V10s, no RS4, no Sport Quattro, no SQ2... Okay, perhaps we won't be shedding too many tears over that last one.

The benchmark is, of course, the Quattro. I'm old enough to have tested late 20-valve examples like the one we have today when they were new and recall most of all just astonishing point-to-point pace. But even though the Quattro had been on the market fully 10 years by then, I don't recall it feeling old.

It does now. The strange driving position, even stranger gear ratios, arcade-game electronic dashboard and acres of hard plastic all speak of another era. The gearbox is quite clunky, while the engine is surprisingly lethargic off-boost, even for its age. At low speeds, it feels quite awkward, rattly and cumbersome. A disappointment, you might even say.

But then the revs rise and you hear that noise (how to →



Quattro had a 2.2-litre turbo five-pot



Porsche boosted it to 311bhp for RS2



TT borrowed turbo four-pot from Golf



Naturally aspirated 4.2 V8 is stunning



Today's V8 sports twin turbochargers



These three Audis are separated by 27 years of development



These hot Audis are rather disparate in character



Audi won the constructors' title of the World Rally Championship with the Quattro in both 1982 and 1984.



“
At low speeds, the Quattro feels quite awkward.
But then the revs rise and you hear that noise...
”



New RS6 Avant is a £93k technological tour de force



The Quattro steers deliciously and has a chassis to match



Back to the '80s with hard plastics, digital dash and tape deck



Driving seat feels superb and those dials are just ace



TT's curvaceous and minimalist aesthetic is continued inside



Incredibly, the stick is even better to use than it is to look at



From LCD to TFT: RS6 is full of tech and super quality



“ The RS2 Avant will still surprise you by how hard it hauls. If only it were as good at changing direction ”





The new RS6 Avant produces exactly three times the power (591bhp) of the original Quattro of 40 years ago (197bhp).

← describe it without saying ‘off-beat thrum?’) and discover that what has not diminished one bit over the decades is the sense of occasion. It’s still fast enough to be engaging, clocking an easy 120mph before that unforgiving shape finds it increasingly hard to bludgeon the wind asunder.

It’s still fun, too. Grip, the commodity for which it was most famed 30 and 40 years ago, is actually quite modest by modern standards and it still understeers, but the steering is lovely and the chassis is far more adjustable than I recall.

That’s not something I’d say so readily about the RS2 Avant. Like so many of the crazily rapid RS estates that followed it, the RS2 is absolutely at its best in a straight line. But it also feels from a far more recent era, for while they missed each other by just three years, the Quattro and RS2 feel a generation apart. The latter is a modern car, you might say.

It’s incomparably better built, and from far better materials. This may have something to do with the involvement of Porsche, which was in such dire financial straits at the time that it had to earn money on the side by engineering cars like the RS2 and, before it, the Mercedes-Benz 500E. Zuffenhausen’s involvement certainly explains how the output of essentially the same engine rose from 217bhp in the Quattro to 311bhp for the RS2.

The car remains as funny as ever. It looks brilliant and oozes promise as you settle into the chunky Recaro driving seat and survey those black-on-white dials. Lag is, of course, prodigious from a 26-year-old road car engine providing more than 140bhp per litre, but once it’s past about 3500rpm, it will still surprise you by how hard it hauls, and over an unexpectedly wide powerband. It hit 140mph in the same space the Quattro needed to reach 120mph.

If only it were as good at changing direction. It clings on, of course, but we must remember this was the first of the doggedly understeering high-speed Audis and old habits die hard.

The TT you enjoy for other reasons. I will take engineering over design every day, but you can’t just climb into the TT and set off. First you have to sit and survey the interior, with all of its unique and lovely touches. I understand absolutely why it was such an enormous hit: it looked and felt not like a platform spin-off →



R8 is at its best in Mk1 form with a V8 and a manual shift



RS6 is much more adept at cornering than its forebears

FIVE MORE SIGNIFICANT QUATTRO CARS



1984 SPORT QUATTRO
The Sport is the 1984 Group B rally homologation special Quattro with mad looks and a comically abbreviated wheelbase. With 306bhp, it was the fastest Audi road car ever produced. And with just over 200 examples made, it remains the rarest to this day.



2008 RS6, RS6 AVANT
Yes, this is an Audi A6 with a twin-turbocharged 5.0-litre V10 derived from the normally aspirated version fitted to the Lamborghini Gallardo. And with 571bhp, very little less 12 years ago than the new RS6 Avant has today, it was absolutely as nuts as it sounds.



2008 Q7 V12 TDI
In many ways, this is the craziest Quattro car yet, here not because it was great per se but because it remains the world’s only diesel-powered V12 production car and had 737lb ft of torque. Which meant it could tow Blenheim Palace without really noticing.



2012 RS4 AVANT
For those looking for the best Quattro all-rounder made to date, look no further. It wasn’t the first to use the 4.2-litre V8 from the R8, but it was one so much sharper and more fun to drive than its predecessor. Superb looks and outstanding quality complete the picture.



2020 E-TRON S
Quattro enters the EV era. Electric torque delivery means there’s a greater need for four-wheel drive, while the flexibility of layout makes it far easier to provide than before. Audi’s 40-year love affair with four-wheel drive is about to find itself a new relevance all over again.

← sharing as much componentry with its brethren as possible but a genuinely bespoke product.

It was built properly, too. This one has done 134,000 miles and still feels taut. Perhaps the TT deserves reappraisal from those of us who were slightly sniffy about it when it was new. It's no Porsche Cayman for sure, but its 222bhp 20-valve engine is eager, its six-speed gearbox a genuine delight and its handling more poised and less nose-heavy than I recall.

The R8 is, of course, the anomaly here: it's the only genuine supercar Audi has made, the only mid-engined car and the only closed two-seater. And although its appearance, interior and quality are all very traditionally Audi, the way it drives is not. Indeed, for the sweetness of its engine, the precision of its manual gearbox and the deftness of its chassis, this early manual V8 car is every bit as credible a high-performance driving machine as any standard Porsche 911 or Aston Martin Vantage from the same era.

It may be rather lacking in horsepower compared with a modern R8, but it's still plenty fast enough to register over 150mph in short order and more than sufficiently rapid to feel restricted by the confines of the public road. What's more, unlike so many quick Audis, it's a car of the most exquisite balance, and I mean that both literally and figuratively.

First, it's refreshingly resistant to understeer and, despite almost unlimited traction, very happy to tuck its nose into an apex and let its rear run wide. But second, it doesn't feel overpowered: the relationship between power and grip is spot on, allowing you to slip easily into a delicious rhythm, which is a defining characteristic of a great driver's car.

That brings us to the RS6 Avant, which is interesting – and not just because it has 591bhp and will do 0-62mph in 3.6sec. What holds my attention more firmly is a distinct sense that, at last, Audi is trying to do this kind of car slightly differently.

Yes, it ticks all the boxes from outlandish power to outrageous appearance, but such strengths in the past have flattered mainly to deceive. However, with a more neutral set-up and a far greater feeling of agility (thanks no doubt to four-wheel steering), it's not just comical in a straight line (it indicated 180mph with ease on Bruntingthorpe's currently abbreviated runway) but also has something to offer on the perimeter road. It's still not the best-handling fast wagon out there, but it has better steering, sharper turn-in and more front-end grip than any big Audi estate of my acquaintance.

So, it would be hard to overestimate the benefit to Audi of that little word 'quattro'. It started life as a niche product with very modest ambitions and became, as Quattro GmbH, the halo brand for the entire brand. Yes, it was renamed Audi Sport back in 2016 (which I always thought a shame), but the idea of using Quattro not just as a technology for making its cars easier to drive but as standard-bearer for the marque, emblematic of its entire philosophy, has played a pivotal role in the transformation of Audi from the bit player also-ran it was in the 1970s to the enormous organisation it is today. It may not have saved the company, but it is no exaggeration to say it helped make it.

As for our famous five, it seems iniquitous to order cars so separated in time, space, performance and concept. But I'll share with you now that there are some really good cars here and one absolute titan.

The Quattro has significance and charm, but it feels pretty limited these days. The RS2 isn't as rounded in its abilities as you might hope, but it's hilarious, it looks great and it's by far the rarest. And for completely different reasons, both the TT and RS6 are far better than I expected. But that early manual R8? Wow. It's not just a great Audi, it's one of the finest examples of that kind of car from its or indeed any other era. **A**



15in alloys look tiny in modern context

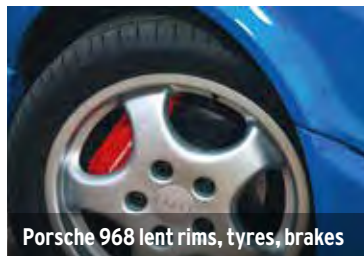

Porsche 968 lent rims, tyres, brakes



Mk1 TT offered 16in, 17in or 18in alloys



Spindly rims reveal powerful brakes



22in wheels, 30% tyre aspect ratio...



Michèle Mouton won the 1981 Rallye Sanremo in an Audi Quattro, becoming the WRC's first female victor.



TT is more enjoyable than we credited it for back in the day

THE DIFFICULT SECOND ALBUM

After 11 years of sterling service, the Audi Quattro was retired in 1991. And, of course for a car that had done so much to transform the image of Audi, it was replaced. It seems odd that they chose to drop the Quattro name that had done so much good,

but the S2 coupé looked great, was bang up to date, had a far better interior and, after 1993, even came with six gears.

Yet despite all that, it never managed to capture the magic of the original – nor even get close. It was fast for sure but less sharp – more a businessman's tool than a road warrior's toy. It never rallied or raced. It was, in truth, just another car. It lasted only four years in the marketplace and had no successor.



S2 was hot version of the 80-derived Coupé

“
 For the sweetness of its engine
 and deftness of its chassis, this R8
 is every bit as credible as any 911
 ”

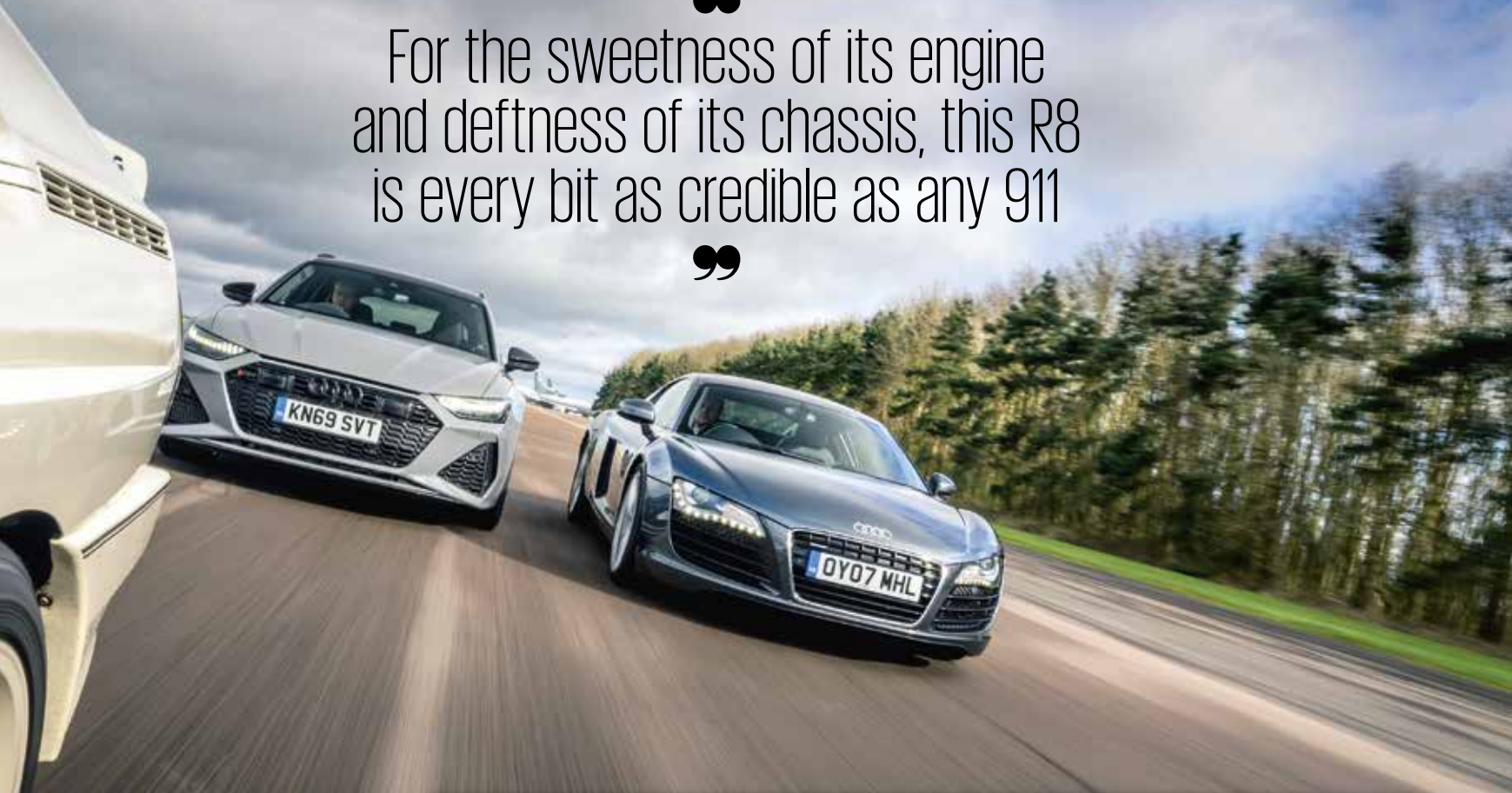

	AUDI QUATTRO 2.2 20V TURBO	AUDI RS2 AVANT	AUDI TT 1.8T 225 QUATTRO	AUDI R8 4.2 FSI QUATTRO	AUDI RS6 AVANT QUATTRO TIPTRONIC
Price	£32,995 (in 1990)	£45,760 (in 1994)	£29,470 (in 1999)	£76,532 (in 2007)	£92,750
Engine	5 cyls in line, 2226cc, turbocharged, petrol	5 cyls in line, 2226cc, turbocharged, petrol	4 cyls in line, 1781cc, turbocharged, petrol	V8, 4163cc, petrol	V8, 3996cc, twin-turbocharged, petrol
Power	217bhp at 5990rpm	311bhp at 6500rpm	222bhp at 5900rpm	414bhp at 7800rpm	591bhp at 6000-6250rpm
Torque	228lb ft at 1950rpm	302lb ft at 3000rpm	207lb ft at 2200rpm	317lb ft at 4500rpm	590lb ft at 2050-4500rpm
Gearbox	5-spd manual	6-spd manual	6-spd manual	6-spd manual	8-spd automatic
Kerb weight	1380kg	1595kg	1465kg	1560kg	2075kg
0-62mph	6.5sec	5.4sec	6.6sec	4.6sec	3.6sec
Top speed	141mph	163mph	151mph	187mph	189mph (delimited)
Economy	na	na	30.4mpg (NEDC)	19.3mpg (NEDC)	22.6mpg (WLTP)
CO₂	na	na	223g/km (NEDC)	349g/km (NEDC)	283g/km (WLTP)



Hot Audis have often been a bit po-faced, but not these three

From start to finish

The original Audi TT seemed revolutionary in 1998, and the Mk3 still has a unique appeal today. **Mike Duff** takes the two for a spin to consider the past and the future

PHOTOGRAPHY MAX EDLESTON



Great design is always a victim of its own success. Familiarity might not always lead to contempt, but it certainly breeds indifference. The original Audi TT has long since become an automotive background artist, a near-invisible part of any streetscape that rarely gets a second glance. Yet when it was new, it drew attention better than most supercars. I'm serious. Back in 1999, I got to drive an early TT coupé through central London months before UK sales started, and it was as if I were

in a low-flying spacecraft or handing out £50 notes. On a gridlocked Euston Road, a bus driver heading in the opposite direction abandoned his double-decker and crossed several lanes of traffic to demand to know what this vision from the future was. Another bloke offered to buy it for cash, which might have caused some mild friction with the Audi press office had I accepted. Not bad for a car that shared its underpinnings with the Mk4 Volkswagen Golf. Yet now the TT is nearing the end of its life. Audi has said there are no plans for a direct replacement

for the current, third-generation model, which will reach its sixth anniversary this year. Market tastes are changing as aspirational punters move to crossovers, and the TT has certainly enjoyed a good innings. But this also feels like a good time for a retrospective to celebrate both the car and the dying segment that could be termed the everyday coupé. Parts-bin special sounds like an insult, but here it isn't. To use it acknowledges the TT's greatest strength: the fact that it isn't an uncompromising, pure-bred sports car. When compared with more

dynamically focused rivals, the TT pretty much always finished runner-up; Audi must have a cupboard full of wooden spoons somewhere from all the comparison tests that it lost. Yet, with the exception of the Porsche Boxster and Cayman, it outsold the sportier alternatives and has outlived most of them. That was thanks in part to the practicality that came from the humble underpinnings: the utility of a tailgate and four seats. You could carry a bike in a TT or more than one passenger, provided they were small enough to squash into the back. →



Original TT's old-school steering is far more feelsome



Third-gen TT was a return to form after the forgettable Mk2

Shifting through the Mk1's six manual gears is a highlight



Today's car has a fairly firm ride but handles pleasantly



SOFT IN THE MIDDLE

When the Audi TT's obituary is eventually written, one thing will be clear: the original and third-generation versions are the ones to go for. A spin in a Mk2 from Audi UK's heritage collection was a reminder of just how difficult it is to replace an iconic car.

Not that there's much evidence Audi tried too hard with the second TT. There are design riffs on the original with all the zip and precision of a geriatric pub band and it's almost as uninspiring to drive as it is to look at.

The interior is particularly dull; the fact it shares its heater controls with the first R8 might be the most exciting thing about it. One for collectors to skip over.

WHAT'S NEXT?

While Audi insiders have said there are no current plans for a direct TT replacement, the company is well aware of both the affection held for the dynasty and the need for future models capable of delivering a similar level of emotional engagement.

When we spoke to Audi technical development boss Hans-Joachim Rothenpieler in March last year, he said: "There's a future for an icon, but I don't know if it's a TT."

Success has many fathers, with plenty of designers keen to have their involvement with the TT acknowledged. The two biggest influences were Freeman Thomas, who sketched the original 1995 concept, and Peter Schreyer, who translated most of that magic into the production model. Special mention is also due to Romulus Rost, who did the groundbreaking interior. Twenty years later, the TT often features on lists of the most influential car designs. Schreyer still owns and regularly drives one, despite having been design head at Kia since 2006.

The TT went on sale in Europe in 1998, but only briefly. Several high-speed crashes in Germany suggested a lack of aerodynamic stability, so production was halted while a wedgy rear spoiler and standard stability control were added. Earlier cars had ESC retrofitted but not the spoiler; the car you see here is one of the tiny number of right-hand-drive examples built early enough not to have it.

That's why Audi UK recently bought it for its heritage collection, although they agreed to let us borrow the car for this story before giving it any cosmetic attention. So it still has the patina of dings, scratches and even rust bubbles that reflect 21 years and 128,000 miles, behind which the core design looks remarkably fresh for something in its third decade.

The form is still striking if you look beyond the familiarity, the curves and surfaces on show without any fussy detailing. Next to it, the latest

TT looks muscular and more modern, but also like a hand that has been played far more safely.

The first-generation TT's interior is impressive now; it was off the scale for a mainstream car 22 years ago. The metal rotary controls around the air vents still feel great (Audi used pretty much the same thing in the A3 until the new version) and the combination of brushed metal and dark trim gives what still feels like a 2020 aesthetic. It feels smaller than I remember: the front seats are set close together, while the rear pair barely qualify as plus-tuos.

The boosty power delivery of the turbocharged 1.8-litre engine is entirely as I recall it. Audi offered 178bhp and 222bhp versions from launch, with a 148bhp unit arriving later. The company has opted to preserve a version packing 222bhp, that being delivered with more enthusiasm than finesse.

The chassis balance is also no surprise. It's front-led but not in a bad way; all early TTs had the Haldex part-time four-wheel drive system, which diverts power rearwards only when the front is running short on grip. So while it's easy to accelerate to the edge of understeer, neutralising a widening line is easily done by lifting the throttle. It's an easy car to drive at a high percentage of its capability.

Time has changed some other subjective opinions, however. In 1999, the TT didn't stand out for having notable steering feel, but the numb electric helms of modern



Two decades on, the original TT remains a joy to drive

THE BEST USED TTs YOU CAN BUY



Mk1 TT 1.8T 180 QUATTRO

Anyone looking for a collectable early TT must kiss many frogs to find their prince. But there are pre-spoiler cars for sensible money, especially left-hand-drive ones that were parallel-imported. Prices range from £2000 upwards; we discovered an early, spoiler-free LHD coupé for £3000.



Mk1 TT 1.8T QUATTRO SPORT

Although there was a VR6-powered range-topper, the most desirable Mk1 TT is the limited-run Quattro Sport, which received a 237bhp version of the 1.8-litre turbo engine and substantial chassis changes. Values are already rising and cars don't come up often; a good one will cost around £10,000.



Mk3 TT RS TFSI QUATTRO

Among faster TTs, the five-pot RS versions already have a cult following and look set to be fondly remembered as such cars grow increasingly rare. Early examples of the ludicrously fast 395bhp Mk3 TT RS are dropping into the mid-£30,000s now. They will fall further but at a gentler pace.

Unique cockpit layout still seems an excellent idea



“
It's still more than fast enough
to keep the modern TT honest
”

machines mean there now seems to be a pleasant degree of chattiness through the thick rim of its wheel.

Nor do I remember the shift action of the six-speed manual being so slick and accurate, the TT being one of those cars that encourages you to change gear even when you don't really need to. In terms of raw pace, it's still more than fast enough to keep the modern TT honest.

Our Mk3 comes from the bottom of the range, a front-wheel-drive 194bhp 2.0-litre, intended to provide context rather than thrills. Yet I'm soon pleased that Audi sent it rather than one of its more potent models, because it shows how the TT has matured over the years. Sitting on the Volkswagen Group's ubiquitous MQB platform means the current car is tauter and is much more refined, with a keener front end and markedly less roll. It feels bigger and more grown-up, simply because it is – a point made by a glance into the back and at the almost-usable rear seats.

But despite a dual-clutch gearbox in place of the tactile challenge of a manual, there's still a pleasure to be had in driving at everyday pace; it's not always goading you to go faster.

There's lots of intelligence in the third-generation TT, too, unlike the lacklustre Mk2 (see box, left). It was never going to have the impact of the original and it didn't try to be a tribute act for its famous predecessor – rather clever in its own right. I still like the idea of its decluttered interior, where the only screen is the digital instrument display behind the steering wheel and there's no glaring distraction on top of the dashboard. It's a handsome, desirable car.

It's also a reminder that the bottom of the range has always made more sense than the top. There have been faster TTs, and some of them have been pretty good, but they've always served to emphasise how far Audi's natively front-driven coupé is from being a purpose-built sports car.

Spiritually, the TT is closer to a hot hatch, one that offers desirability and modest excitement at an affordable price. As such, it's almost a latter-day Ford Capri – and yes, that is intended to be a compliment. If Audi does replace it with something, whether that's an EV or a creation even more radical, that new car will have a mighty challenge to match its rational-emotional appeal. **A**

At 2500kg and with 1200bhp, the Drako has a power-to-weight ratio of 500bhp per tonne. Yet Jay Leno said in his video review that "it doesn't actually feel that fast". He's right: it doesn't.



A LOAD OF BALBONI

It was rather a shock for Colin Goodwin to bump into Lamborghini's legendary former test driver at the launch of a Silicon Valley electric car. What's the deal?

PHOTOGRAPHY JAMES LIPMAN

Well I never, if it isn't Valentino Balboni, the legendary Lamborghini test driver. He's possibly the last person I'd have expected to bump into at the launch of an electric hypercar. The car in question is called the Drako GTE and the place is Thermal Raceway in California.

I wasn't expecting to be here myself, but I'm staying with a photographer pal who's shooting the car for the journalists and other media at the event. We recently ran a feature on Thermal (22 January) and I was curious to see it for myself.

It's great to see Balboni here. He was always the coolest of the Italian test drivers. Ferrari's Dario Benuzzi

is a pretty slick dude but also a rather more polished act than Balboni – a bit more designer shades. When you got in a Lamborghini with Balboni, you felt that you were in the car with a proper mechanic and craftsman. He would roll up his sleeves and get stuck in. Boy did he get stuck in.

This GTE is a bit of a thing. It was born in Silicon Valley, the project of electroboffins Dean Drako and Shiv Sikand. Drako isn't here today, but the quick-talking, very passionate and clearly intelligent Sikand is. The car itself is powered by four electric motors, making it, he points out, the only quad-motor EV that exists in the metal (well, if you ignore Mercedes-Benz's late SLS AMG Electric Drive).

As you might have already guessed

from looking at the photos, the Drako is based on the Fisker Karma. The doors are the same but the rest of the carbonfibre body has been tweaked by ex-Pininfarina designer Lowie Vermeersch. It isn't ugly, but it does have a visibly enormous wheelbase. A 90kWh battery pack containing 10,000 cells sits under the floor, which explains why. The four motors drive the wheels via half-shafts and produce a combined total of 1200bhp.

Balboni is being interviewed on camera. This should be interesting. What does he think about high-performance EVs? "They're the future, for sure," he says. "The days of the traditional supercar are coming to an end." He's right, of course, as the plethora of super-EVs in development

shows. I suspect also that Balboni, a guest here today, is being somewhat diplomatic, so I'll get him alone later.

'Alone' is sitting next to him in the Drako. The last time I met Balboni, I was driving a slightly scuffed Diablo SV into the car park at Sant'Agata. It had been teeming with rain and I had been unable to make a mountain road corner in the non-ABS-equipped and summer-tyred Lamborghini.

"Ah, yes," says Balboni. "A blue one with orange SV lettering on its side." He remembers. He was fine about it at the time; he just wanted people to drive his cars with gusto and passion and expected the odd bit of collateral.

Balboni answered the questions in a matter-of-fact way, just as I would have done. Yes, EVs are the future,

Goodwin and Balboni recall old escapades with Lamborghinis



“He hammers the car around, accompanied by whirrings and a lot of tyre squeal”

but don't expect me to weep with joy at the prospect. The real Balboni comes out when I talk about the old days and his first love, the Miura, and mention that I had lunch with his old gaffer, Gian Paolo Dallara, last year.

We're in a different world now. Last time I was his passenger, there was a loud V12 behind us and he was about to pull out of the factory gates and into the Emilian countryside with his foot flat to the floor. In the Drako, there are just odd whirring noises and the whining of cooling pumps.

Different environment, same old rolled-up sleeves, same talent. Balboni hammers the Drako around Thermal's multiple corners with the accompaniment of more whirrings and a lot of tyre squeal. This car weighs 2.5 tonnes, and you can feel

that even from the passenger seat.

The Lamborghinis that Balboni developed weren't exactly light or easy to drive fast, so this is no great challenge for Il Maestro. There's plenty of time to catch up and talk joyfully of old times, because the Drako has to spend quite a lot of time suckling from a large and very noisy diesel generator. Drive super-EVs on track and you get a lot of coffee time.

“We lived through a golden age of the sports car,” says Balboni, becoming more wistful by the moment, “with a freedom to drive and enjoy cars that no longer exists.”

Indeed: a period in which an Italian policeman would have been put on parking meter patrol if he had been stupid enough to give Balboni a speeding ticket in a Countach. **A**

RIDING SHOTGUN IN THE DRAKO GTE

Shiv Sikand explained at length the advantages of having four electric motors and how an enormous amount of work has gone into the electronic control and software that vectors torque between them, front to back and laterally. Total control.

When you're out on the track, you feel that all this electricricker is employed in keeping the Drako on the asphalt, controlling its weight and enabling the Michelin Sport Cup 2 tyres to last more than a couple of laps. The brakes are huge ceramic discs, which do the job, but they're just one part of the system: it's telling that the Drako has to have its brakes bled halfway through the event.

The Nissan GT-R (which is a bit too technical for my taste) uses its demonically clever systems to enhance the experience: you can feel the torque moving

around the car and helping you to drive it faster. Apart from on one occasion when I felt the Drako launch itself out of a corner with a wriggle, there's no emotion to the experience of going fast in this car.

The \$1.25 million (£1m) Drako won't be homologated for sale in Europe, so all 25 examples to be built will be for American or Middle Eastern customers. While the car is a job well executed, I won't miss it.

Thermal Raceway is rather like the Drako GTE: very impressive but ultimately a bit unemotional and soulless. I think I'd get bored of thrashing around the place pretty quickly.



The Drako corners neatly, but you still sense its huge heft



Our man talks tech with Drako's Shiv Sikand

Depending on who is at the wheel, the condition of the track surface and the car itself, you can probably expect to get about two full laps out of a set of tyres under proper drift conditions.



GET THE DRIFT

Turn in, shake the rear loose and hold it there... Just how tricky can it be to drift a car? Trickier than it sounds, as **Simon Davis** learns the hard way

PHOTOGRAPHY LUC LACEY

An S-chassis Nissan rounds the corner with the length of its heavily modified body wildly perpendicular to the apex. Its highly strung gazillion-horsepower engine is screaming in furious protest as it bounces off the limiter, while plumes of white smoke erupt from the rear wheels with the ferocity of a full-on pyroclastic flow. A metre or so from its rear bumper, a similarly modified Mazda RX-7 matches the leader's absurd angle of attack, and in tandem the two cars link slide after dramatic slide as they make their way around the tight, technical circuit.

But despite the cacophony of thrashed engines and screeching tyres, their movements are all beautifully composed and coordinated. In fact, they're so graceful you might even find yourself wondering just how hard the process of getting a car to behave in such a manner can really be.

Having been guilty of harbouring similar thoughts in the past, I was keen to get to the bottom of this drifting malarkey once and for all. And so, brimmed with the sort of misplaced confidence that can only come from spending a bit too much time watching drift videos on YouTube, I arrived at Drift Limits Motorsport Academy in Hertfordshire ready to get stuck in.

The plan was simple. Instructor Bill and I would head out in a second-generation Mazda MX-5 to cover the basics, before switching things up in a more powerful Nissan 350Z later in the morning. Everything going well, I'd have progressed from total drift novice to someone who could link a few slides together with something resembling coherency by the end of the session.

Now, although the cars we'd be using were by no means modified to the extent of those used in competitive drifting, they weren't entirely



Saint Bill of Bovington reminds Davis how it's done

stock. Their rear diffs had been welded, and a few suspension tweaks had been implemented to make them that much easier to slide and to rein in unwanted body roll. The dedicated track we'd be using was also lubricated with a high-tech mixture of vegetable oil and water because, y'know, we newbies need as much of a leg-up as possible.

“
It takes roughly four years of solid practice to be able to drift like a pro
”



Davis uses the full width of the track to give himself space

embarrassing given the low speeds we were travelling at.

I'd accelerate up to a mighty 23mph on corner approach, lift off the gas a car's length or two ahead of the entry point, feel the weight shift gently forward off the rear axle, turn the wheel, feel the car begin to slowly rotate, stab and release the throttle to amplify the slide, miss the catch by applying either too much or too little throttle, and then either end up straightening up or facing the opposite direction. Frustrating. The MX-5's short wheelbase made it feel particularly snappy, while my novice's desire to be actively doing something with my hands and feet only exacerbated the inevitability of my failure.

Bill was incredibly patient. He gently reminded me of the importance of letting the car work for you and emphasised the need for patience when it comes to making your inputs. In fact, allowing for the momentary pauses between each step so you can really feel what the car is doing and tune into how its balance is shifting beneath you is just as important as the steps themselves.

After more practice, I'd become comfortable with the initiation phase and was set to tackle the catch. Here, the pause between the initial stab of throttle and its reapplication is crucial, but after a few more failures, I got my timing right and managed to power on through to the corner exit. Although there's still a lot to think about in terms of balancing steering and throttle inputs, this final phase feels a lot more intuitive than the catch.

A quick break to let everything stew, and then it was back out in the 350Z to try to link a few slides together. Immediately, it felt like an easier car to manage. Its longer wheelbase made its rotational movement that much more progressive and easier to read, and

the process of initiating, catching and then holding a drift came more naturally.

Now it was time to link a few slides together. This is the point where drifting really becomes an art form and also where you really need to ignore the urge to follow a classic racing line. The closer you get to the track extremities, the more room you have to initiate your next drift.

Timing and patience are once again key here. You need to stay on the power for as long as possible at the end of the previous drift, before lifting to begin the initiation process over again. The car swings like a pendulum beneath you, you catch it, and transition into the next drift.

I nearly completed an entire lap by the end of the session. Nearly. Given where I'd started out, the fact that I'd got this far in just a few hours was immensely satisfying and a testament to Bill's impeccable tuition and saint-like patience. Nonetheless, he reckons it takes roughly four years or so of solid practice to be able to drift seamlessly like a pro.

But once you're there, he said, the scope of your imagination really becomes the only limitation. Those drivers who aren't afraid to be creative, who are willing to push the boundaries of their abilities and experiment, are easily the most exciting to watch. Just like any artist, really. **A**

IT'S NOT JUST DRIFTING

Autocar snapper Luc Lacey had a hand in setting up Drift Limits in 2011. In the beginning, it was just him and founder Jonny Barden, a Mk2 MX-5 and a wheelbarrow that was used for mixing cement. Among other things, Lacey recalls spending hours using that cement to manually fill the potholes that littered the taxiways of Bovingdon Airfield – the former RAF bomber base where the company is still based today.

Although Lacey is no longer involved, Drift Limits has grown significantly over the years – thanks in no small part to its commitment to offer driving experiences at more affordable prices. Today, in addition to the drift school, you can have a go in homologated race cars such as a McLaren 12C GT3 and do stunt driving courses. There's also the 'police pursuit', which sounds hilarious. Who wouldn't have fun fleeing a professionally driven Dodge Charger police car in a Porsche Boxster? Find out more at driftlimits.co.uk.

In 2018, BMW set the record for the longest continuous wet drift undertaken in eight hours. An 'F90' M5 covered 232.5 miles sideways, with a mid-drift refuel courtesy of another, similarly sideways M5.

After a quick sighting lap to learn the circuit's layout, Bill ran me through the basics. In its simplest form, there are three main phases. First is the initiation, where you lift off the throttle to move the car's weight forward, turn in with about a quarter lock on, and quickly stab and release the accelerator to initiate the slide. Then you need to catch the drift with a more sustained application of gas. Finally, you maintain the drift through to corner exit by balancing throttle and steering inputs. All the while, you need to let the car do as much of the work for you as possible. Sounds easy, right?

The reality is, of course, entirely different. Learning the steps is one thing. Actually executing them successfully is another challenge altogether. So rather unsurprisingly, my first few attempts at getting the Mazda out of shape resulted in me spinning almost immediately, which felt rather

Drift experiences in an MX-5 start at £98 at Drift Limits





FEELING IT

With the rise of electric steering, a lack of steering feel has become a common gripe. But what is actually meant by this, and why does it matter? **Andrew Frankel** explains

This might seem a bold thing to say, but here goes: there's not a single attribute more important to the enjoyment of a car than the feel for the road derived through its steering. I'll go further: there's no single reason for the erosion of driving pleasure in recent years greater than the continued and continual loss of that feel. But what exactly is this feel whose passing I so lament?

When I teach younger writers about the business of road testing, it's the subject most likely to be raised, perhaps alongside determining the difference between primary and secondary ride. And for them it's a real problem, because it's

hard to explain and harder still to understand. But for you who aren't charged with reaching opinions and justifying conclusions about your cars, you shouldn't be troubled at all.

Indeed, the reason I'm writing this is because a reader took the time to write in (thank you, Daniel Vernon), complaining that the Vauxhall Astra he drives has steering that's too light and lacks feel relative to that of the Ford Focus he owned in the past.

What's interesting here is that Daniel hasn't merely spotted a problem – his new car isn't as good to drive – but has also identified its cause. I've heard countless people make this complaint over the years, but few know what lies at its heart. "I just really liked the way my old

car drove" is the most familiar refrain. And I would bet plenty that, nine times out of 10, what has gone missing is steering feel.

It's true that I'm somewhat old-school about this, which is partly a factor of my age and partly because I spend my spare time driving old cars, which, rubbish as they may be in very many ways, have steering feel that almost any modern car simply wouldn't recognise.

There's a younger cohort of writers and drivers who attach less importance to steering's feel and more to its accuracy, linearity and weight, and I'm not saying they're wrong just because I take another view. Traditional steering feel has played a far smaller role in their

automotive education and, as a result, it quite understandably matters less.

But what exactly is steering feel, and why is it in such short supply these days? On one level, it's precisely as it's described: how does the steering actually feel. On a less literal but more important level, steering feel is a car's ability to communicate both accurately and clearly through the steering apparatus information about how the road and its conditions are being managed as the car flows over its surface.

To complicate matters a little, a distinction needs to be drawn between desirable feel or feedback and unwanted kickback. You absolutely want the steering to create a very real sense of connection

between you and the road, but you just as strongly don't want the steering leaping around in your hands or threatening to break your thumbs every time you inadvertently drop a tyre into a pothole. It is, therefore, something requiring very skilled suspension engineering.

Yet all the combined knowledge, talent and technology that exists in the world today hasn't stopped steering systems becoming ever more mute. And, as ever, there's no one reason for this. The fact that cars have become heavier hasn't helped, nor has the fact that, partly in response to this, cars have been fitted with ever wider and heavier tyres, all of which compromises steering feel.

But the pantomime villain of the piece goes by the name of EPAS, better known as electric power-assisted steering. When it was realised that EPAS systems were cheaper and less troublesome than traditional hydraulically assisted steering, they must have looked pretty tempting, but what caused their near-wholesale adoption was that they allowed manufacturers to achieve slightly lower official fuel consumption figures and therefore lesser CO₂ emissions.

When the first Porsche 911 with EPAS came out (the 991 in 2012), I persuaded an engineer to tell me exactly what the saving would be in the real world, which I then calculated amounted to two free tanks of fuel over a decade on the road. To me, that wasn't worth compromising the single most important interface between man and machine, especially in a car like the 911.

Why does EPAS kill steering feel? Because, as our own Jesse Crosse puts it:

"EPAS's reputation for dead feeling over centre and general lifelessness was due to the effects of internal friction, freeplay ('lash') and the rotational inertia inside the electric motor, which is magnified at the steering wheel by the system's own gearing." So now you know.

But there's another, even more persuasive reason why steering feel has become so hard to find these days: most people don't actually want it. You and I may want to sense an intimate connection to the road, but those who regard cars as mere transport – which is most people – don't want anything of the sort. They want to be removed as far as possible from the sensations of driving, cocooned in their own little world. And in that regard, EPAS is only too ready, willing and able to oblige.

Even so, it remains a matter of choice for manufacturers. They can take the CO₂ hit and continue to use HPAS – although among major companies, McLaren alone ploughs this lonely but noble furrow and will continue to do so until it finds an EPAS system that can mimic feel so well that you can't tell the difference.

If your car is light enough, you obviously don't need assistance at all, which is really the way to maximise steering feel. But even within the world of EPAS, the range of outcomes is enormous. Developments in EPAS pumps, the way they're mounted and particularly the algorithms that control them have transformed what's possible in the past decade.

So, if your car still has little or no perceived steering feel, the sad truth is likely to be that its manufacturer either couldn't be bothered to engineer it in or actively didn't want it there. If so, drive a car from a company that does. **A**

CARS WITH EXCELLENT STEERING FEEL



Volkswagen Golf

Volkswagens tend to steer well, and the Golf's mixture of decent feel and linear responses promotes senses of enjoyment and stability.

Ford Fiesta

Ford has always paid singular attention to feel, so the Fiesta's steering is class-leading by far.

BMW 3 Series

BMW made great efforts to reconnect the driver to the road with the G20, which is why it's the most enjoyable exec out there.

Toyota GT86

When it was new, the GT86 set new standards for EPAS steering in an affordable car, and it's still superb.

Porsche 911

The 911's steering is as good as you can currently get with EPAS, although still not up to the HPAS standard that it left behind in 2012.

Any McLaren

HPAS means there's no need for steering feel to be synthesised; you feel what you feel because that's what's happening. And there's still no substitute for it.

Toyota GT86 set new standards for EPAS back in 2012



Almost invariably you'll find better feel in older cars



McLaren is the only mainstream user of hydraulic assistance



“Steering feel is a car's ability to communicate information”



No supermini feels better in your hands than the Ford Fiesta

BRINGING UP THE REAR

Rear-wheel steering systems are once again in the spotlight, but the idea isn't new. James Mills picks 10 pioneers of the corner-taming technology

Ot shouldn't come as a great surprise that one of the most hotly debated automotive chassis technologies originated in Japan, a nation whose residents appear to be born with a fascination for high-tech gadgets and gizmos.

Active rear-wheel steering was introduced in 1985. Fittingly, it made its debut on the Nissan R31 Skyline, a car as synonymous with innovation as noodles are with ramen. However, the technology was popularised by the 1987 Honda Prelude, which was sold globally.

The benefits of active four-wheel steering were highlighted early on by American magazine Road & Track. In 1987, it took a Prelude 2.0Si 4WS, laid out a slalom course and

pitched the Honda against sports cars from Chevrolet, Ferrari and Porsche. The humble Japanese saloon beat the lot of them.

As with so much innovation, the novelty value of four-wheel steering diminished as the years passed by. At the same time, insurers grew wary of repair bills – any car equipped with the costly hardware faced big repair bills if hit from behind. Rear steer systems faded away.

Until, that is, engineers realised that as cars of all shapes and sizes were getting larger and heavier, active rear-wheel steering systems could help make them more manoeuvrable, be it in a car park or around a race track.

Here are 10 highlights, past and present, of models that belonged to the rear steering committee.

BMW 850 CSi

Want to know the reason why the flagship 850 CSi version of the E31 8 Series is so cheap these days? Its Aktive Hinterachs-Kinematik (AHK) system has a habit of going wrong and more often than not costs an eye-watering amount to fix. The car was powered by a 5.6-litre V12 with 375bhp and benefited from the input of BMW Motorsport. Trouble was, it came at a cost – almost £80,000, in the early 1990s.



HONDA PRELUDE

The Prelude was the car that brought four-wheel steering into the public eye. Its system was able to steer the back wheels the same way as the fronts, by 1.5deg and up to a steering input of 246deg. Apply more lock and the back wheels were able to point in the opposing direction by up to 5.33deg, giving the Honda a compact turning circle of just 10 metres, or 33 feet in old money. However, the cost of the complex steering gear didn't go down well with insurers when a Prelude was hit from behind.



XEDOS 9

Hands up who remembers Xedos. The quasi-upmarket Mazda spin-off enjoyed modest UK success with the 6, but the bigger 9 never really took off. Perhaps that's because the UK version made do with the active four-wheel steering system made available on Japanese versions.



LAMBORGHINI URUS

Lamborghini made great strides with the updated Aventador S, which came with a four-wheel steering system that then found its way onto the Urus. It was a key ingredient in creating a high-performance SUV that didn't sully the reputation of Italy's second-best-known sports car maker.





MITSUBISHI 3000 GT

The 3000 GT was laden with nearly as many gizmos as Doc Brown’s DeLorean: active aero aids, all-wheel drive, adaptive suspension, two turbochargers and, of course, four-wheel steering. However, few of Britain’s drivers were drawn to it when they could have a BMW or Porsche instead.



FORD F-150 PLATINUM ZF

When a car is 5.8 metres long and has a near 14-metre turning circle, the thought of negotiating a multi-storey car park is enough to bring out a cold sweat. It’s why the latest Ford F-150 gets a ZF rear-wheel steering system. Ford has since applied for a patent for such a system on the current F-150.

PORSCHE 911 GT3

While it was the 918 Spyder that Porsche first fitted with an active rear steering system, the first relatively attainable model was the 991-era 911 GT3. The company’s engineers did a good job because, after the first drive of the new model, Autocar reported: “If Porsche had not revealed its existence, we may never have noticed it.”



FERRARI F12TDF

With nearly 770bhp to manage, the limited-edition F12tdf needed all the help it could get when it came to keeping things on the black stuff. For the first time, Ferrari introduced a rear-wheel steering system, which it called a ‘virtual short wheelbase’. Remarkably, the ZF-sourced hardware added just 5kg to the kerb weight, which had been reduced by 110kg over a standard F12. The tdf was a challenge to drive at the limit but its steering tech filtered through to models including the GTC4 Lusso and 812 Superfast.



RENAULT MEGANE RS

It may seem like overkill in a hatchback but Renault Sport’s engineers have used the latest generation of four-wheel steering – called 4Control – to their advantage, making it adjustable according to the conditions and ideal for track days. Renault says steering angle is reduced by up to 40% compared with a Mégane without the system.



NISSAN 300 ZX

In 1990, Nissan struggled to convince UK drivers that a company best known for the Micra could rub shoulders with Porsche, so 300 ZX sales soon slowed to a negligible number. Although there was much to like, opinion is divided over whether or not to disable the High Capacity Active Steering (HICAS) four-wheel steer hardware.



EAT YOUR HART OUT

Tom Hartley has made millions dealing supercars. Colin Goodwin visits his new place

PHOTOGRAPHY JOHN BRADSHAW

Two days ago, a text arrived from Tom Hartley's personal assistant, Hannah, asking what filling I'd like in my sandwiches. Attention to detail: that's Hartley. It has been a while. Eighteen years back, I took Hartley, probably the world's most famous peddler of supercars, to the Geneva motor show. If your memory is better than mine, you might recall the resulting feature. Hartley brought his son Carl, who was 13 then and is now a full partner in the business. But more about the family later.

We're at Hartley's establishment in Overseal, near Swadlincote, Derbyshire, for a couple of reasons. First, Hartley wants to show off his recently completed new showroom. Second, he wants to talk about his new autobiography, *The Dealmaker*.

Establishment isn't the official description; Hartley refers to the place as The Hartley Estate. Quite a place it is, too. Visits are strictly by appointment only, and if you did think about turning up at two in the morning to help yourself to the McLaren P1 that's currently in the front of the showroom (alongside

a huge selection of other exotica), you will have to crack a formidable security system.

Your other problem is that Hartley not only lives on the estate – in a very grand gaff in the middle of it – but also doesn't sleep much, so you're likely to be caught red-handed. While you and I are in the land of Nod, the hyperactive 59-year-old Glaswegian will most likely be cutting a deal. Deals deals deals.

If you read his book, you'll be up to your neck in deals. And celebrities. And money. The book was ghost-written by fellow hack and ex-Sun

motoring scribe Ken Gibson. In parts it's an excellent manual for the budding entrepreneur, with plenty of advice and inspiration, in others a masterclass in self-obsession. It's interesting to discover that among Hartley's business heroes are Philip Green and Mike Ashley (of BHS and Sports Direct respectively) and that he considers Donald Trump a genius.

In the book, Hartley notes that he likes characters rather than bland people, citing fellow car dealers Nick Lancaster and Ron Stratton as falling into the first group. He's right about Lancaster: I have about a hundred



Of all the stunning metal on show, it's this 1972 Ferrari 365 GTB/4 that Goodwin wants

subjects as the sales potential of the Lotus Evija, let's take a tour around and kick some tyres.

Hartley is rightly proud of his new showroom. The old one still exists; it's where his original office is and from where he still works. Carl has an office in the new place with plenty of computer screens and tech on show, while Dad's is an old-school leather-topped desk with a phone on it. For doing deals. In case you've never read anything about Hartley in the media, he's had his office walls covered in old articles and features concerning him, including the one that I wrote.

The new showroom is stunning. It's across three floors, all of which are serviced by a car lift. The top one has a balcony so that cars can be out in the open. The ground floor contains Carl and chief salesman James's office.

There's a big glass panel on the floor so you

can, if you want to, go down to the basement and survey the underbelly of your prospective purchase. The glass had been occupied by a nearly new Porsche 911 Targa, but that has just been collected by its new owner: the wife of a successful East End builder who last week made the trip north to collect his own Lamborghini Aventador SV. Hartley did 500 deals last year, mostly with private buyers but also some within the trade.

Now the sheet of glass is covered by the P1. There's a Bugatti Veyron next to it, several more Lamborghinis and, on the other side of the showroom, a Porsche 918 Spyder and Carrera GT.

I love Lamborghinis and the straight-forward people who tend to buy them. Like that most famous of Lambo owners, Rod Stewart.

"I know what you mean," says Hartley. "I've sold Stewart several cars. He used to live in Epping Forest but now he's up near Harlow. One time, I had to drop off a car at Elton John's house in Berkshire and then go on to Rod's to collect one." →

Hartley is particularly proud of his lake. It has a submerged bridge running across it so that cars can be photographed surrounded by water. He got the idea from seeing a photographer pouring water on the asphalt while photographing one of his cars.

hilarious anecdotes involving him, so it's a bit of a shame that Hartley, who has known him for longer than I have, didn't commit a few to paper.

While Hartley might not come across as your cup of char in this book, he's very dynamic and likeable in the flesh. And if you're into cars, and particularly very fast ones, he's absolutely fascinating. I doubt there's anyone in the world who has a better knowledge of this market or, more importantly, a more comprehensive address book containing the names of those who play in it. But before we question the oracle on such pressing



You can usually spot Hartley stock in the classifieds right away



Younger son Carl is a partner in the business – and a true petrolhead

Some address book.

As well as the P1, there's a 720S and a new GT. "I'll never drive a McLaren again," says Hartley with some feeling. "I suffer from claustrophobia and once got stuck in one because the central locking failed. I nearly had to bash my way out of the thing but fortunately was rescued. They're not at all well made, and then there's the depreciation. That 720S was about £240,000, but you could take it away now with fewer than 5000 miles on the clock for £150,000."

The Evija was mentioned earlier. I remember from when we trod the boards at Geneva that Hartley didn't hold Lotus in especially high regard. "The problem," he explains, "is that, as a brand, it simply isn't on the same level as Porsche or Ferrari. Selling a million-pound-plus Lotus isn't going to be an easy job."

So what does the man who has the most amazing key box in the world drive? "I've got a diesel Golf," is the answer. "It's a great little car. I do of course drive lots of supercars, but

the reason I drive the Golf is that I don't want to lose the special feeling that you get when you drive a supercar. I don't want to become blasé about them. I need to feel what the customers feels."

By his own admission, Hartley isn't a petrolhead, even though his knowledge is certainly prodigious. For a chat with a proper enthusiast, you need to buttonhole Carl.

The boy has turned out well. As covered in his book, Hartley, who left school at 11 himself, home-schooled both his sons and both his daughters. When I met Carl in 2002, I found the experience rather unnerving. A young version of Dad, in a sharp suit, very earnest and very controlled. I couldn't imagine that he would grow up to be a normal person. He has – and we can bond over cars, too.

"What about electric supercars?" I ask. "Not for me," is the emphatic reply. "That's as far as I'll go," he says,

It's possible to pick up a bargain from Tom Hartley – even an affordable one. In stock is a five-mile-old BMW i8 Roadster that cost £130,000 new. Now you can drive it away for just over half that price.

“ Ferrari have started taking the piss out of customers ”



Hartley has always been happy to talk to the press

pointing at the hybrid P1. "Not pure EV, because the engine is the soul."

Carl's brother, Tom Junior, worked with the old man until 2014, when he left to start his own eponymous business, which tends to specialise in classic cars. Top-end ones, of course. There are a few old-timers knocking around Hartley Senior's premises, too: a Lamborghini Jalpa hiding in a corner, plus a Ferrari Daytona and a flat-floor Jaguar E-Type on the top level. Both are immaculate, but the Daytona is just sensational in dark blue. It's my pick of the stock.

A rather more affordable Ferrari is a mint-condition 458 Spider. "These



The showroom currently contains 51 cars for sale

are interesting," notes Hartley, "because they're worth more than the 488, as people prefer the naturally aspirated engine."
This is what makes him so interesting: his deep knowledge and,

because his business isn't a franchise, his willingness to speak his mind. Witness his views on McLaren. He's not shy about Ferrari, either. "They've started taking the piss out of customers," he rails, "with cars like the 488 Pista, which it charges a fortune for but which isn't really that different [from the regular 488 GTB]."
"Also the way that you have to buy several 'ordinary' models like the 812 Superfast and Portofino to get yourself on the list for the more exclusive stuff. Eventually,

they'll come unstuck doing this."
Hartley tends to own all his stock; there are no big loans with the bank. Everything you see has been hard-earned and paid for. This is going to put Hartley in a better position post-pandemic than many of his rivals.
"I've been through several recessions," he notes, "so I know what to expect. I know I'm going to lose a seven-figure sum on this stock, but I'm well placed to deal with it."
I don't doubt it. Hartley's combination of self-belief, experience and sound business acumen should get him through even this steadily tumultuous economic storm. **A**

THE RAREST, THE MOST UNUSUAL AND THE PRICIEST

Hartley has shifted three McLaren F1s in his time, which he rates as some of the rarest cars he's sold.
One of the most unusual has just arrived. "This Ariel Nomad is pretty unusual for us," he says. "Not at all the typical car you'd see us with."
Unsurprisingly, Hartley regularly has to sign confidentiality clauses, so can't talk about some of the deals that he's done. However, the biggest is common knowledge. The ex-Phil Hill Ferrari 250 TR he sold in 2014 for £24 million was at the time the most expensive car ever sold from a showroom floor in the UK and probably the world.



The Autocar archive covers a century-and-a-quarter of motoring

KEEP CALM AND

World wars never stopped us and neither will this pandemic. Colin Goodwin opens the archive to discover how Autocar has kept its readers entertained during national crises

We're carrying on. Of course we are; we always have. Autocar has witnessed a lot of world events and disasters during its 125-year life, but we've continued to produce a weekly magazine throughout. The Autocar was just a few years old when the Second Boer War broke out, but a war being fought in South Africa didn't have much of an effect back home. Anyway, there were only six privately owned cars in Britain when the magazine was first published, and I doubt there were that many more while the Boers were being beaten.

Only twice in its long history has Autocar not made it onto the shelves. There may be a few readers who were alive during the first occasion but probably none who will remember it or whose own reading was interrupted. G guessed it? It was during May 1926, when the General Strike brought the country to a standstill. Still the only general strike ever called in the UK, it ran for only nine days until the Trades

Union Congress and Stanley Baldwin's government managed to come to an agreement. Three issues of The Autocar were lost.

The second occasion many of us were around for, and I'm sure a great number of you remember being starved of your favourite motoring publication. We're talking about the 1973 fuel crisis and the three-day week. Power cuts, sharing baths and, as remembered fondly by this writer, school lessons by candlelight. The miners were on strike and so too were the printers. The latter caused the longest absence from the shelves in Autocar's history: an outage that ran from 15 November 1973 until 23 March 1974. The print unions had achieved something neither Kaiser Wilhelm II nor Adolf Hitler could.

It's amazing that not a single issue was missed during either the First or Second World Wars. Paper could have been a problem, certainly in WW2, because it was strictly rationed, but titles such as The Autocar and Motor Sport were considered important for keeping up morale (hopefully



We produced many stories on army driving and fighting vehicles during the world wars

our cars, mentioning magnetos in particular. He goes on to suggest that, after the war is over, we in Britain should make our own fuel from the by-products of agriculture so that we will no longer be beholden to foreign suppliers, and equally boldly points out that Germany is already doing just such a thing.

The Autocar also played its part in the war effort, as a short news piece in the 10 November 1917 issue shows. The week before, we had run an article on The Red Cross School of Motor Mechanics that had been set up in Vevey, Switzerland, for prisoners of war interned in the country. The editor had pointed out the great work the school was doing to help the servicemen learn skills that would be useful to them in peacetime. He had also asked readers to contribute to the running of the school and a week later had received several hundred pounds. It's good to note that the then publishers of The Autocar, Iliffe & Sons, had themselves put in £105.

By the time the country was at war again, the motoring world had changed dramatically, even though just 20 years had passed. Private car ownership was far more common and there had been two decades of fantastic motorsport. There were more cars and there were better and more exciting cars.

But, as announced in an editorial in the front of the issue dated 26 July 1940, right in the middle of the Battle of Britain, there were no new cars. "Since last Saturday," wrote the editor, "it has been impossible to buy a new car without a licence." Below this piece, we noted that 10 times more people were killed on the roads in June than were killed by air raids. That ratio would be modified that autumn by the start of the Blitz.

While buying a new car was out of the question, there was a plentiful supply of used cars available. The Autocar's classified pages, certainly in the early part of the war, were far better populated than petrol rationing would have you expect.

My nose would have been firmly pressed against the window of Brooklands of Bond Street in London, whose September 1940 advertisement contained such mouthwatering machines as a nearly new Lagonda V12 coupé for £1050 (roughly a seventh of the price of a new Supermarine Spitfire) and, if its country of birth didn't bother you, a 1937 Mercedes-Benz 540K for £595. For the RAF fighter pilot, it surely would have had to be an SS Jaguar 100 two-seater at £295.

The Autocar didn't seem to have much trouble sourcing writers for its wartime articles. Here's a name that may well be familiar to you (no, not Steve Cropley): Denis Jenkinson. The legendary Jenks was working as an engineer at the Royal Aircraft Establishment in Farnborough alongside the equally legendary Motor Sport editor Bill Boddy, who was busy writing flight manuals.



Goodwin was pleased to discover just how resilient we have been

6 Advertisements

The Autocar

Specially Selected Car Bargains

★ **BROOKLANDS of BOND STREET** ★

1932 ALVIS Speed 25 4-door Sports Saloon, choice of two	£675	1932 LAGONDA 12-cyl. 4-door Pillbox Saloon, engine approx. 5,000, painted for guarantee	£875
1938 ALVIS 4.9 4-door Sports Saloon, original approx. AMB, passed by ALPS, as new, list price £1,225	£875	1937 MERCEDES-BENZ Type 540-K Four-door Drop-top Coupe, immaculate	£595
1938 ALVIS 4.5 Sports Saloon by Christie	£545	M.G. 2.6-litre Four-door Drop-top Coupe, car as new	£395
1938 ALVIS Crested Eagle 4-door Saloon, engine 2,000, as new	£495	M.G. 2.6-litre 4-door Sports Saloon, immaculate condition	£395
1937 BENTLEY 4½-litre supercharged two-seater, small mileage	£375	M.G. 1½-litre Saloon, immaculate condition throughout	£275
1938 BUICK Victory Saloon, as new	£375	1938 ROVER 10 h.p. Sports Saloon, exceptional condition	£225
1938 DELAGE 23.4 h.p. 4-door Pillbox Saloon with Continental body	£275	1934 S.S. Jaguar 3½-litre Sports Saloon, black of two, as new	£295
1938 HUNTER Super 21 h.p. Four-door Drop-top Coupe, 400 miles only	£475	S.S. 100 2½-litre Sports Saloon, exceptional condition	£295
1938 LAGONDA 12-cyl. short chassis Sports 4-door Coupe, engine approx. 6,000, as new Mercedes-Benz, ultra-attraction	£1,050	1938 SUNBEAM-TALBOT 10 h.p. Sports Saloon, as new	£250

102, NEW BOND STREET, LONDON, W.1. MAY 1940 2331-4

NEW SPECIAL CARS—FI BEND 1938 AUST 1939 AUST 1940 M.G. 1938 M.G. 1939 ROVER 1939 VAUX CARS WE T SERVIC 235-7-7

“There was always a strong optimism that things would go back to normal”

In the Air
On the Beaches
On the Roads
In the Streets
In the Villages

DUNLOP TYRES
do their Duty!

Ads often boasted of firms' combat roles



As-new SS Jaguar could be yours in 1940 for the equivalent of £16,640

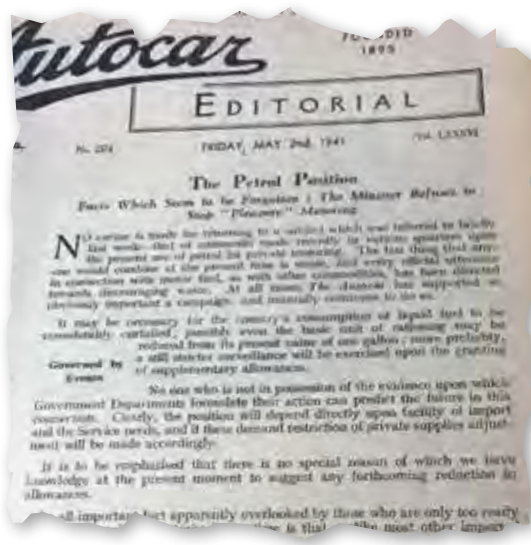

With new car sales banned and petrol rations withdrawn, we gave advice on how to mothball your car



Wide-ranging impact of the oil crisis was felt around the globe

Only strikes in 1926 and 1973-74 have stopped us printing

A Message from the Editor



WITH THE appearance of this issue of *Autocar* ends a regrettable period of absence from the bookstalls that started with the issue of 15 November, and we're as thankful and delighted to be back with you as we hope you will be to see us again.

Not until their "outlet" is taken away from them do the staff of any publication appreciate how much it means to be able to exchange their thoughts and ideas with readers—nor how much of their lives is taken up in amassing material. This is particularly so where such strong common interests as cars and motoring are concerned.

The steady flow of readers' letters—from thoughtfully worded, kindly commiserations to "get well quick" cards—have been the sole bright spot of the period; from them we have learned the extent of the goodwill that exists, and the value you, the readers, attach to your weekly *Autocar*. These letters, a few of which are published in this issue, have meant a very great deal to us.

After the further, long drawn out period of disputes, our original print factory has been closed. We are now with new printers; let's hope we are due for a repetition of our first 70 years of uninterrupted publication.

During our absence we have not been idle. You will see, for example, that we have restyled the pages and improved typography of *Autocar*, giving it a crisper, more modern look without, we hope, wandering too far from what our readers have grown accustomed to. And, since we were never quite certain when publication might be resumed, we prepared material week by week in anticipation. We have, therefore, quite a wealth of exciting features and Road Tests. We regret, though, not having had an opportunity to comment on the recent petrol shortages, and anti-motoring sabre-rattlings during one of the most critical periods in the history of the

Jenkinson contributed to the 28 March 1941 issue a fascinating four-pager on the relative performance of well-known competition machines – a feature that is timeless and would be fascinating to replicate in 2020.

As for racing itself, there of course wasn't any in Europe. The Indianapolis 500 was run in 1940 and 1941 but then stopped after the US entered the war. The *Autocar* didn't forget about motorsport for the duration and instead ran many articles that looked back at some of the great races from the past decades.

Prince Chula of Thailand, cousin of the famous racing driver Prince Bira, wrote several such emotive pieces, including a history of The British Empire Trophy for 4 April 1941.

There was never a shortage of readers' views, either. Here's a cracker from John Bartlett of North London, which begins in the fashion that many of your letters still do.

"Having been a reader of *The Autocar* since 1925, when I was 11 years of age, I have written at different periods in your correspondence columns. However, due to the Dunkirk business, I have returned to civil life minus my right leg but am managing on a metal one."

Mr Bartlett then goes on to describe the arrangement and operation of the disabled driving controls on his Austin Seven that he designed and manufactured himself.

There was a strong feeling of optimism throughout the whole war, even during the darkest periods, that things would go back to normal after an Allied victory. Towards the end, when this was on the horizon, *The Autocar* busied itself with practical matters, such as how to recommission your car.

Even as far back as February 1943, we had been considering the problem of tyres on cars that had been laid up being perished by the time the war was over. The *Autocar*, concerned that post-war new car production would eat up the supply of fresh tyres, urged the authorities to make sure owners of old cars were also supplied.

By 1945, the talk was of the sort of new cars that would be made and how the huge improvements in metallurgy, manufacturing and technology that had been learned in the development and building of war machines would benefit cars. There was excitement also about the restarting of motorsport and the very accurate prediction that the perimeter roads of RAF airfields could be used as racing circuits.

We live in very different times, of course, and are facing different issues with this pandemic. But some things are the same: my colleagues are still beavering away to produce a magazine in challenging conditions, while we're all looking forward to getting out on the road again and to enjoying events like the postponed Goodwood Festival of Speed.

Stay calm and publish. That's the *Autocar* motto. 📖

HOW TO GET YOUR MOTORING FIX WITHOUT LEAVING HOME

Looking for some automotive fun to keep you occupied while sitting round the house? Of course you are. Here are 50 ways to help make self-isolation and social distancing positively entertaining

FILMS AND TELEVISION

The Sweeney (plus other '70s shows)

There's great pleasure to be had from watching reruns of classic TV shows like *The Professionals* and *The Sweeney*. It's not just the fights and shooters, it's the glorious '70s backgrounds containing cars. There are Austins, Rovers, Jaguars, Lancias and Renaults, to name just a few. Talking Pictures TV is showing *Out*, featuring a 1978 Ford Granada 2.8 and rock-hard Tom Bell as an ex-con getting revenge. Brilliant. **JR**

On Any Sunday

With pioneering use of helmet cameras, slow motion and innovative high-speed filming trickery, it's hard to believe that this early stab at the motorbike racing exposé dates from nearly 50 years ago. Director Bruce Brown introduces the flourishing motocross scene, calling on Steve McQueen for narration services and taking in some of the sport's most death-defying exploits and charismatic participants. Think of it as a bike fan's version of *Drive to Survive*. **FP**

30 for 30: Qualified

Since there's no live sport at the moment, BT Sport has been showing loads of ESPN's excellent 30 for 30 documentaries. It's worth watching out for *Qualified*, which tells the story of Janet Guthrie, the first female racer to qualify for and compete in both the Indianapolis 500 and Daytona 500. Besides the inspirational tale of perseverance, there's the awesome mid-1970s Indy footage. **JA**

C'était un rendez-vous

Every second of Claude Lelouch's 1976 cult classic is thrilling. Shot in a single take, the eight-minute film depicts a high-speed, high-stakes drive through early-morning Paris. Despite the distinctive V12 howl that plays throughout (said to come from Lelouch's Ferrari 275 GTB), legend has it he was actually at the wheel of his Mercedes-Benz 450 SEL 6.9 for the run. Regardless, this is one of the greatest film soundtracks ever. **SD**

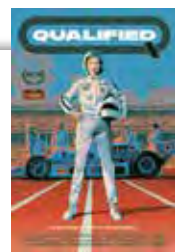

BOOKS

A RACING DRIVER'S WORLD

By Rudolf Caracciola

Few early grand prix drivers survived long enough to pen autobiographies, but Rudolf

Caracciola's is pretty special. The hugely talented German raced for Alfa Romeo and Mercedes-Benz between the 1920s and 1950s, won six German grands prix as well as a hard-fought Mille Miglia in 1931 and survived numerous crashes. He had a brilliant turn of phrase: "A man is a racing driver as another is a hunter." Or: "After each accident they look for new safety measures, but death finds ever new ways to catch his victims." **MD**



HELLO WORLD

By Hannah Fry

Okay, so this isn't technically about cars, but a significant chunk of Hannah Fry's brilliantly accessible book is given over to autonomous vehicles. Delving into the theory, the technology and, most fascinatingly, the psychology of driverless cars, this carefully researched account reveals that we're further away from letting the machines take over than some areas of the industry would have you think. **JD**

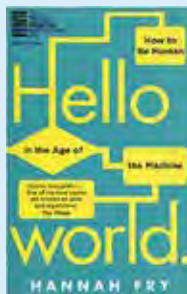

CAR GUYS vs BEAN COUNTERS

By Bob Lutz

Maximum Bob was always a journalist's dream, ready to shoot from the hip and mouth off at anyone and anything. What's more, he was (usually) forgiven for some of his less well-judged commentary on account of whatever he said coming from the heart, as well as the perspective of a car guy. Lutz's written works are prolific, so there are a few to choose from, but this tale built on how he helped turn around General Motors by focusing on decent profit rather than big margins is a belter. **JH**

THE UNFAIR ADVANTAGE

By Mark Donohue

Mark Donohue's life story is told through the prism of all the cars he raced in formulae from Trans-Am to Indy, Can-Am to F1. The clarity of the man's brain is mind-boggling, while the phlegmatic descriptions of the cars he drove make them appear somehow even more magical. It's a book about a superb engineer, incredible driver and fine human being, tinged with the sadness of knowing he would lose his life so soon after it was completed. **AF**



BANGERNOMICS BIBLE

By James Ruppert

Come worship at the high priest's altar with the one and only, truly original paean to buying a second-hand car that won't break the bank and which you'll fall in love with. James Ruppert himself describes it as "futureproof and universe-friendly", by which we think he means that everything you read in it will be as true tomorrow as it is today. So popular was this genre-definer that not even Ruppert has any copies left today - but he will sell you a "thoroughly modern PDF" for a scarcely believable £1.97 via his Bangernomics website. **JH**





The Autocar YouTube channel

Forgive the blatant self-promotion, but on Autocar's YouTube channel (760,000 subscribers can't be wrong), there are more than 1000 videos for your perusal. News, reviews, group tests and silly features: there's something new every week. And all for free. Like and subscribe guys, like and subscribe. **MP**

Used Cars

Here's an '80s screwball comedy with cars, lots of cars: mostly dented, often anonymous, square Chevrolets and chrome-filled '50s/'60s Fords. It also contains the great Kurt Russell and even greater Jack Warden, a brilliant old Hollywood character actor.

For reasons revolving around used car lot rivalry, the plot is all about amassing a mile of used cars. I won't spoil it, but there's one hell of a wild ride getting there. **JR**

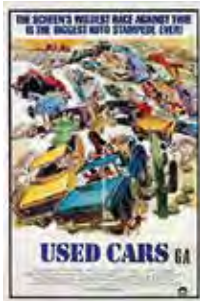

Grand Prix

As beautifully shot as Steve McQueen's Le Mans but vastly superior as a film on account of actually having a plot. James Garner – as big a petrolhead in real life as McQueen or Paul Newman – excels in the lead role, but it's a great film for spotting cameos from the racing drivers who helped make it, including Graham Hill as Bob Turner. It's fun spotting which are real F1 cars and which are dolled-up F3 cars, too. **AF**

Uppity

This is the story of Willy T Ribbs, a decently talented racing driver who faced into – and sometimes broke down – social barriers as a black man in a white man's sport. A Formula Ford champion in the UK, Ribbs (who enticingly recounts his gripping tale with no lack of confidence about the scales of his talent) ran out of money but made acquaintances who gave him shots in F1, Nascar and Indy – some successful, some less so. **JH**

Apex: The Secret Race Across America

It's The Cannonball Run in real life, and it doesn't get much more dangerous or exciting than that. Rapper Ice-T and former Gumball Rally lunatic Alex Roy explore the underground US transcontinental races inspired by the film, including Roy's highly illegal but thoroughly rehearsed 2006 attempt to break the 1983 coast-to-coast US driving record of 32 hours and seven minutes in a modified BMW M5. Strap yourselves in for a wild one – and don't think about having a go yourself. **LA**



Drive to Survive

Fallen out of love with F1 recently? You're probably not the only one. As drivers and team managers become increasingly media-trained and the budgets ever more obscene, personalities have taken a back seat. But this insightful Netflix series gives refreshingly candid access to the behind-the-scenes sagas and bitter team rivalries, showing the true characters in F1. With races postponed, this is an essential watch. **LA**

HOW TO BUILD A CAR

By Adrian Newey

How you would begin to design something so incredibly complex as a car is mystifying to most of us, and even more so when it comes to the pinnacle of motorsport. Who better to hear about it from, then, than F1's most successful designer ever? Part autobiography part handbook, and spanning from March 881 to Red Bull RB8, How to Build a Car lifts the curtain on factory goings-on, analyses key elements of car design and describes engineering innovations in understandable terms, aided by clear technical drawings. **KC**

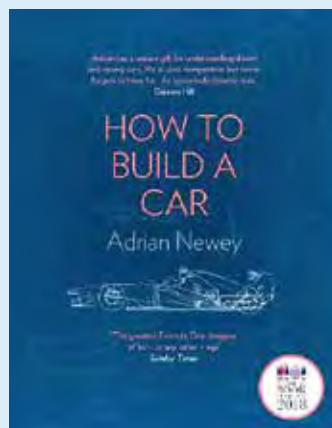

HIGH PERFORMANCE

By Peter Grimsdale

When I was a lad on a website called 4Car, Peter Grimsdale was the nice man at Channel 4 who supported the site greatly. What I didn't know then is what a great storyteller he is. High Performance is a ripping yarn of Britain's motoring exploits in the glory years. Recommended. **MP**



CARS: ACCELERATING THE MODERN WORLD

By Brendan Cormier

Those of you who have visited the V&A's Cars: Accelerating the Modern World will know how utterly captivating the exhibition is. Here's the next best thing: this coffee-table book curates the highlights of the show, ranging from the rise of Fordism to the early days of racing at Brooklands in the 1920s to the Firebird 1 concept car of 1953, intended to look like a jet fighter. Finally, it brings us to the modern day, considering the place of electric and autonomous vehicles in society. **RB**

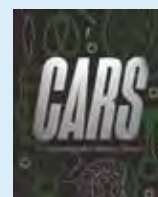

HAYNES MANUALS

Come clean now: how long has the Haynes manual for your slightly problematic, ageing motor been sitting on the bookshelf untouched? Now's the time to dust off the cobwebs and get to serious grips with fixes for your car. Once you've run out of inspiration there, Haynes now offers advice on an array of subjects, ranging from 'Vegan Man' (yes, really) to the International Space Station. You know you're tempted. **RB**

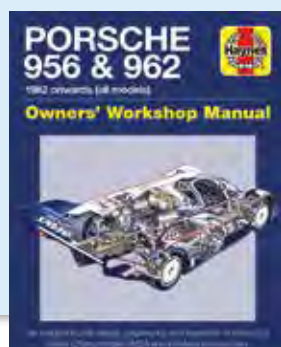

DRIVING WITH THE DEVIL

By Neal Thompson

This book digs into the fascinating relationship between early stock car racing and moonshine running in America's Deep South, focusing on a handful of complex, colourful characters who have long been left in the margins of Nascar history. Come for crazy tales of illegal alcohol deliveries and early oval racing, stay for the political battle that led to the rise of America's biggest motorsport. Think F1 politics with added southern draws and guns. **JA**



WEBSITES AND ONLINE

Circuit-spotting on Google Maps

This is an activity that can keep you occupied for weeks. With a bit of time, research and the Google Earth app, you can visit any track you choose – but the obscure and forgotten ones are best. Trace the layouts of places like Germany’s Südschleife, Crystal Palace in the UK or even Spain’s recently abandoned venue in Valencia. **JD**

Online emulators

Computer games were better in the old days, right? Well, dig around the Internet Archive (archive.org) and you’ll find a host of in-browser emulators, allowing you to play some old racing classics, such as the Commodore Amiga version of Lotus Esprit Turbo Challenge. Be warned: they’re not all as good as you remember. **JA**



Classic & Sports Car Classifieds

You know how sometimes a nagging ache is enough for you to tell yourself you won’t take feeling well for granted? This reminds me of that, but on a bigger scale: life’s too short to own boring cars. And Classic & Sports Car has loads of interesting ones. **MP**



The Samba

You might not have a project car in the garage that you can work on in times like these, so why not watch someone else finish theirs? This US-based forum, aimed at classic Volkswagen owners, allows readers to track the course of Beetle, Microbus, Buggy, Karmann Ghia and even vintage Porsche builds from start to finish. **FP**



Esports sim racing

With motor racing postponed for the foreseeable future, ‘real’ racers are going online to take on sim racers, and you can watch it live or streamed. Some good fun that could very well exceed your expectations. Search ‘The Race’ on YouTube for the best of it. **MP**

Grace’s Guide

Upon his retirement from the world of industry, Andrew Tweedie set about shedding light on the fascinating early history of British industrialism by founding Grace’s Guide. The charity is run by volunteers with niche areas of knowledge, and its daily updated encyclopaedic website currently has some 139,000 articles and 225,000 images for you to enjoy, covering companies, people, events, machines and inventions. Autocar (founded 1895, doncha know) has proved one of the key sources of information. **KC**



Car configurators

Shortly after Land Rover unveiled the new Defender, it put its online configurator for the model live. Within seconds, social media was flooded with ‘here’s one I made earlier’ creations. Sure, they’re ultimately there as buying tools, but configurators have become a source of entertainment by themselves. **JA**

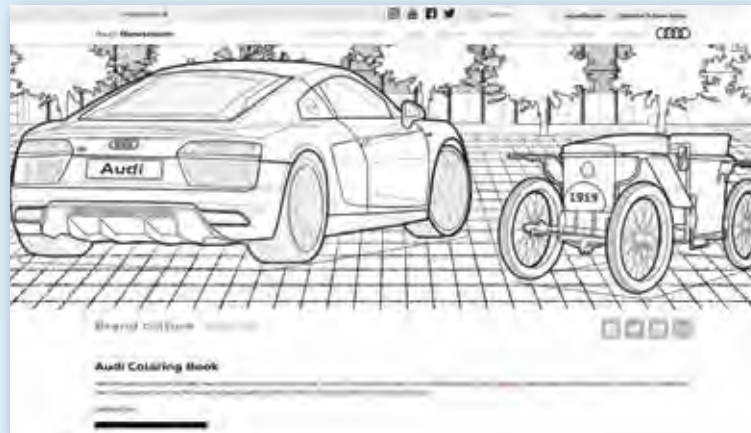

Download car colouring books

Need to occupy kids? Well, get them colouring in some cars. Audi is offering a free-to-download colouring book (audi.us/33JasCr), while former Jaguar design chief Ian Callum’s new agency has put some designs on callumdesigns.com/downloads. Actually, both look much too fun to set aside for the kids... **JA**



VHS Rallies

An anonymous rally fan has dedicated this channel to rescuing footage gathering dust on video cassettes and bringing it into the digital world. And we should all be grateful. The result is a hotchpotch of action from jaw-dropping rally talent from yesteryear (loosely speaking the Colin McRae-and-Richard Burns era backwards), plus several amusing specials, from 1981 champion Ari Vatanen in a jacket and tie on Sport Friday to national rally hero Gwyndaf Evans being interviewed while driving a school bus. **JH**



Archive video on YouTube

Experience joy by watching racing at Brooklands in 1935. Kay Petre clocked 134.24mph in her 12-cylinder Delage, making it the fastest lap yet driven by a woman. The defeated Gwenda Stewart shook her hand at the end and said with all the grace she could muster: ‘Jolly good show, I’m very glad you won.’ Yeah, right. Squint and you can see The Autocar advertised. **RB**

COMPUTER GAMES

Grand Theft Auto

So GTA is not a 'conventional' driving game, but there are cars, there is driving and there are missions to complete that involve both. It just happens that there's quite a bit of carnage and bloodshed, too. 18-plus. Don't show your gran. **MP**

F1 2019

With no real events, Formula 1 bosses have thrown together a series of all-star races using the F1 2019 game. Still, the official F1 game is even better to play than watch, so why not find out if you could have denied Lewis Hamilton his sixth title last year. **JA**



Gran Turismo Sport

Nearly three years since it was launched, Gran Turismo Sport remains the standard to beat for classic driving simulators. Whether it's gruelling online racing, relentless lap-time shaving around the Nürburgring or just the neat livery customisation feature, there's plenty to enjoy. But a racing wheel is essential equipment to make the most of the impressive physics. **LA**



Mario Kart Tour

Mario Kart might be the antithesis of hardcore sim racing, but underpinning its cutesy graphics has always been sharp handling and challenging tracks. This smartphone redux makes the transition to touchscreen well. Still brutally cruel when you dominate a race only to be whittled out by a red shell. **JA**



Dirt Rally 2.0

The successor to one of the best rally simulators of all time, Dirt Rally 2.0 refines the physics, visuals and gameplay. Everything from a Lancia Fulvia to brutal Group B cars and today's unstickable WRC models are available on all the greatest rally stages, mixing varied weather and surfaces to test your skill. **LA**

Mudrunner

Based in the wilds of Russia, Mudrunner tasks you with delivering logs across huge open-world maps, dodging muddy bogs and mountains. It's tough and requires extreme patience, but the physics are amazing – you'll find yourself doing lots of slow-speed crawling, juggling diff locks and planning your fuel. It's way more fun than it sounds, honest – and you get to drive huge Russian eight-wheelers. **BSY**

Forza Motorsport

Physics nerds will probably prefer the Gran Turismo franchise's attention to detail when it comes to suspension behaviour and bumps in tracks, but Forza will let you make a faithful replica of your local plumber's Ford Transit, whack in the V6 from a Jaguar XJ220 and then tear around the Nordschleife. **FP**

OTHER THINGS TO DO

CHECK OUT YOUR FAVOURITE VIEW (VIRTUALLY)

One of the simplest joys of driving is pointing your car towards locations you love, aka scenery. I do it all the time, sometimes diverting from long motorway hauls for the purpose. But in these times of essential travel only, we'd suggest the next best thing: Google Earth. Find roads and check out the view virtually, so you know where to visit when the situation allows. **SC**



PLAN A ROAD TRIP

Now's not the time to round up your mates and tackle the North Coast 500, so take extra time to plan your next big road trip. Be ambitious: imagine you've got a couple of weeks to spare, the ideal car to drive and enough spare cash. Who can create the best bucket list? **FP**



HOME DELIVERY

Rocket League

Rocket League couldn't be further from a racing simulator if it tried. It's basically arcade-style online multiplayer car football with customised radio-controlled cars. It doesn't sound like much, but it's absurdly addictive and easy to follow. **LA**



Grand Prix 4

The most recent version of Geoff Crammond's outstanding series dates from way back in 2002 – Lewis Hamilton's first full season in car racing – but such is its accuracy and popularity that it's supported and kept fresh by an active online modding community. **JA**

Motorsport Manager 3

An ideally pitched management game for smartphones. You get to juggle the many jobs of a team boss – sign drivers and staff, develop parts, chase sponsors, plot race strategy – while avoiding getting bogged down in



tedious minutiae. It's also available in a more in-depth form for PCs. **JA**

BUY A MOTORBIKE

Social distancing isn't going to be much fun in this context, but it is when you have a motorcycle to ride, it's a nice day and the roads are quiet. So take your new-found free time to hunt on the internet for the ideal bike. **MP**



TAMIYA RC CARS

Ah, Tamiya radio-controlled cars. Happy memories of childhoods past and just as relevant and entertaining today. They take days to build, mere seconds to crash. **MP**



LEGO TECHNIC DEFENDER

It's Lego. It's a Defender. It has opening doors and working steering. It has an inline six-cylinder engine with moving pistons. And, most important, it has 2573 pieces. It's not a toy, it's a proper engineering project. **JA**

AUTOCAR

Since you're reading, it's likely that you appreciate Autocar as a valuable source of car-related escapism and entertainment. So don't miss out if you get stuck at home: try our digital edition or subscribe and have the magazine delivered to you (visit autocar.co.uk for details). The mag also doubles as the world's glossiest toilet paper in emergencies. **JA**



MODEL KITS

If you're of a certain age, you'll know the joys of turning a sprue of odd grey plastic shapes, some nasty-smelling glue, a few miniature pots of paint and a set of decals into a lovely model. The quality and level of detail has improved since your youth. The likes of Airfix, Revell and Tamiya offer car kits in various scales ranging from the Bentley Blower through the Tyrrell P34 to the, er, Buick Grand National. **KC**



BUILD A CATERHAM KIT CAR

This will be my third Caterham kit but the first one that I've built for me and not for a magazine. Also the first one that'll be a keeper. An for that reason, and because we have a lot of time on our hands due to this pandemic, it will be built more slowly and to a higher standard. The kit is comprehensive so, as long as you've got things like axle stands and trolley jacks (which I have) and a good tool kit, you shouldn't need to leave home. What a pleasure. **CG**



TIDY THE GARAGE

For years, my garage has been basically a lifestyle overflow zone – a place for things with no place. Now the lockdown means I'm out of excuses to impose order, first by fixing the door that was broken in the storms – box ticked – now by having a proper clear-out and finally sorting out my tool mountain. I also need to somehow make space for my Porsche Cayman so it doesn't spend another summer under a sap-dripping tree. **MD**



MAKE A GAMING RIG

Okay, you've got the game, but the joystick doesn't cut it and a wheel clamped to a table shakes. With a bit of dedication, some metal or wood or bolts or welding, you too can have a home 'simulator'. Props if your other half will let it stay in the living room. **MP**